

CONTI-V MULTIRIB® multiple V-ribbed belts

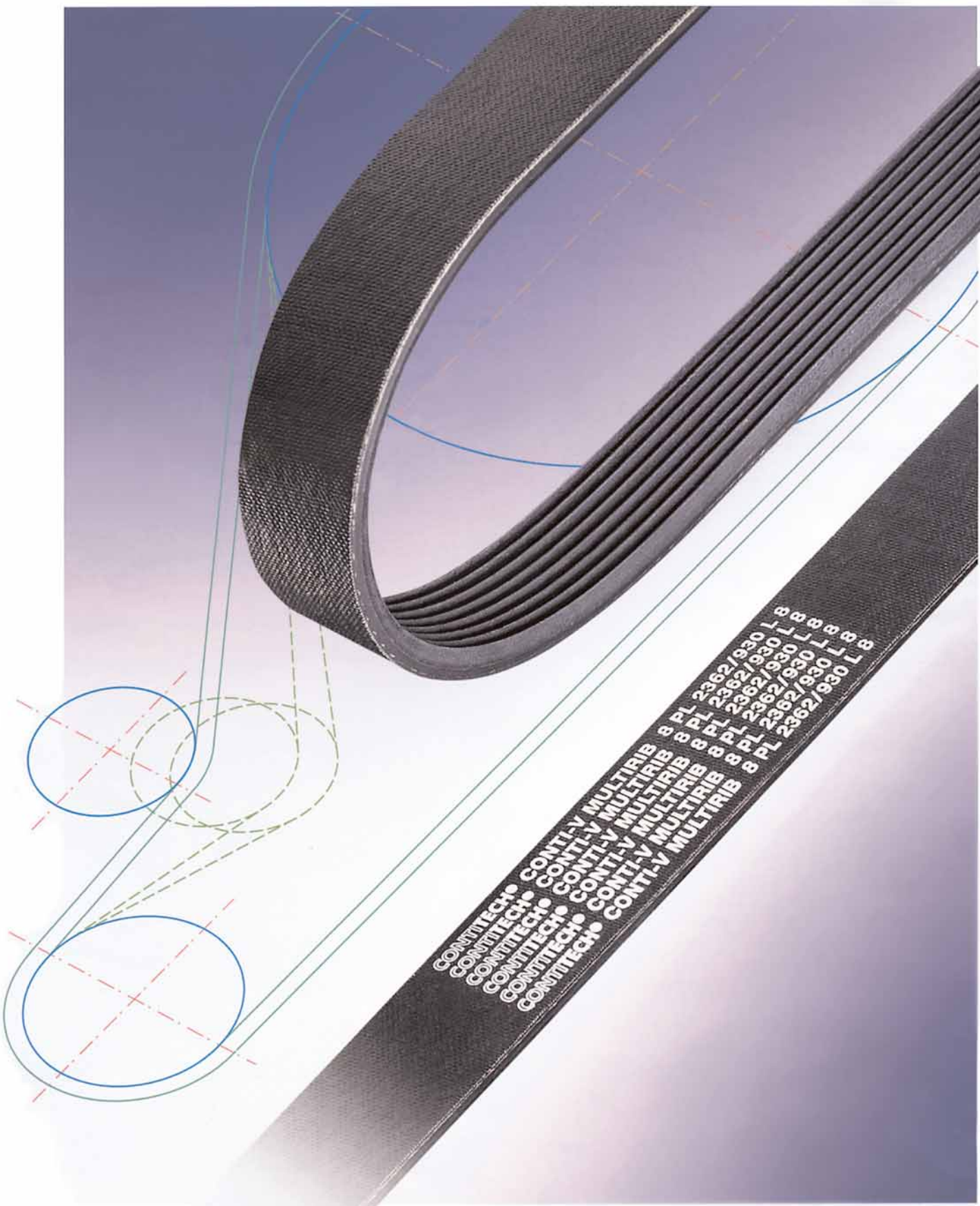

CONTITECH® CONTI-V MULTIRIB 8 PL 2362/930 L 8 8
CONTITECH® CONTI-V MULTIRIB 8 PL 2362/930 L 8 8
CONTITECH® CONTI-V MULTIRIB 8 PL 2362/930 L 8 8
CONTITECH® CONTI-V MULTIRIB 8 PL 2362/930 L 8 8
CONTITECH® CONTI-V MULTIRIB 8 PL 2362/930 L 8 8
CONTITECH® CONTI-V MULTIRIB 8 PL 2362/930 L 8 8

ContiTech
Specialist in rubber
and plastics technology

The ContiTech Division is a development partner and original equipment manufacturer for many branches of industry: with high-grade functional parts, components and systems. It is part of the Continental AG with 8 business units specialising in rubber and plastics technology and utilising their common know-how.

That's what the ContiTech brand is all about.

CONTITECH 

3-10 **1 Product description**

- 5 ___ Construction
- 5/6 ___ Properties
- 6 ___ Designation
- 7 ___ Available sizes
- 8 ___ Standard lengths
- 9 ___ Length tolerances
- 9 ___ Length measurement

11-20 **2 Multi-grooved pulleys**

- 12 ___ Selection and application
- 13 ___ Sizes
- 13 ___ Designation
- 14 ___ Diameters
- 14 ___ Tolerances
- 14 ___ Surface finish
- 15-19 ___ Multi-grooved pulleys with taper bushes, standard range
- 15/16 ___ Multi-grooved pulleys for section PJ
- 17-19 ___ Multi-grooved pulleys for section PL
- 19 ___ Taper bushes

21-54 **3 Calculation of multiple V-ribbed belt drives**

- 22/23 ___ Glossary of symbols, units and terms
- 24-31 ___ Drive calculation data
- 32-41 ___ Power ratings
- 42-45 ___ Power ratings for ZAR type
- 46-48 ___ Example of design procedure steps
- 49-53 ___ Calculation of a multi-grooved/flat pulley drive
- 54 ___ ContiTech drive design service

55-59 **4 Notes on design**

- 56 ___ Tensioning pulleys
- 57-59 ___ Crossed drives

61-63 **5 Installation and storage of multiple V-ribbed belts**

- 62 ___ Installation
- 63 ___ Storage

64/66 **Index**



Construction

Available sizes

Properties

Standard length

Designation

Length tolerances

Length measurement

Product description

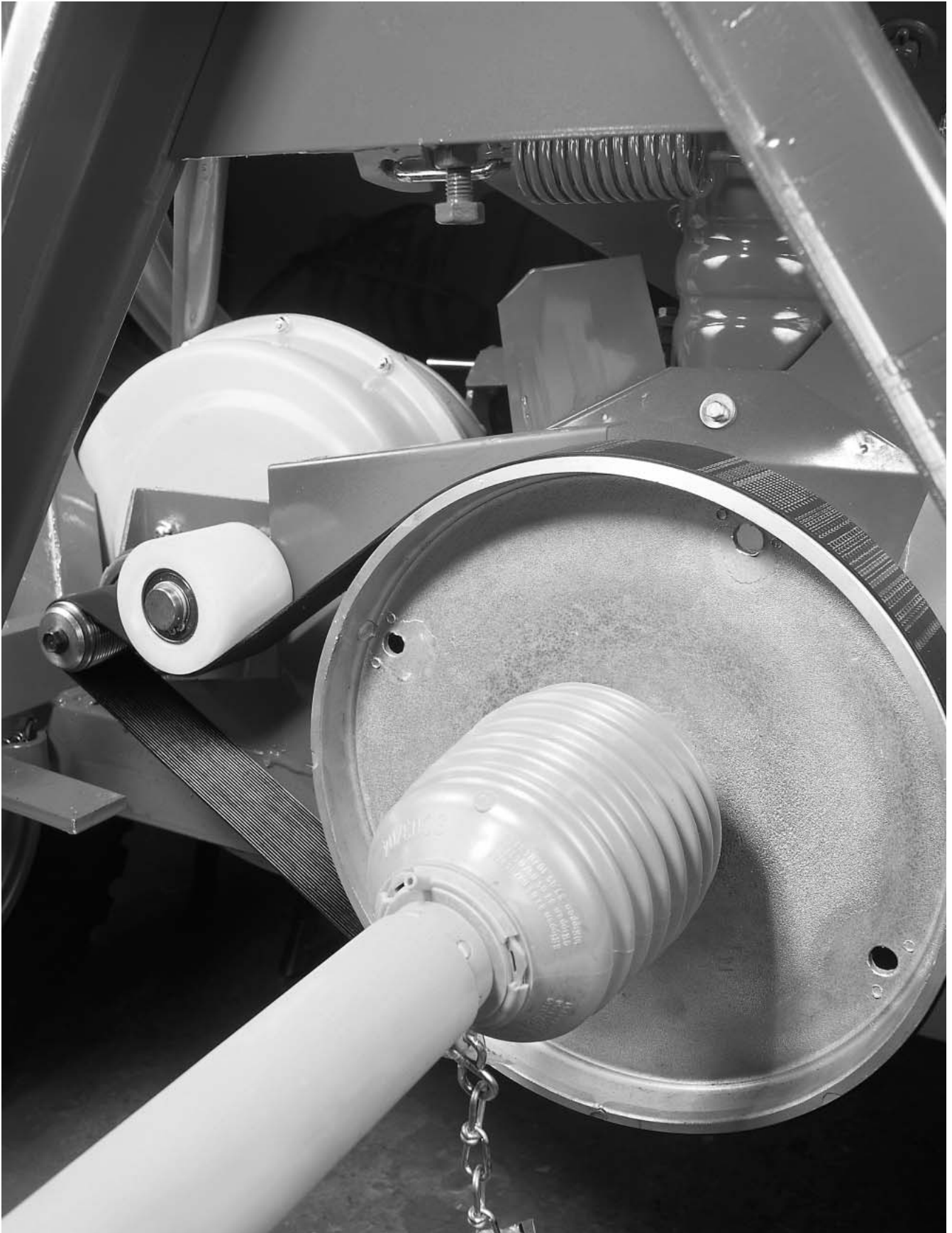

CONTI-V MULTIRIB® Multiple V-Ribbed Belt
in a grain drill

Greater design flexibility with CONTI-V MULTIRIB® Multiple V-Ribbed Belts – for high transmission ratios, high belt speeds and serpentine drives.

CONTI-V MULTIRIB® Multiple V-Ribbed Belts are the result of constant further development of CONTI® Power Transmission Products. They combine the high flexibility of flat belts with the high power transmission capacity of V-belts.

CONTI-V MULTIRIB® Multiple V-Ribbed Belts allow low cost design, even with difficult drive system requirements such as high transmission ratios, high belt speeds, small pulley diameters and reverse-tensioning idlers.

They are particularly suitable for serpentine drives and provide a reliable and highly efficient element of friction transmission, compact drives.

CONTI-V MULTIRIB® Multiple V-Ribbed Belts are available in 5 section sizes capable of transmitting anything from just a few watts to 20 kW per rib, and so cover a host of different applications from household appliances to heavy-duty machinery.

Modern production techniques and constant inprocess quality checks guarantee products with maximum reliability and high quality standards.

CONTI-V MULTIRIB® Multiple V-Ribbed Belts are versatile and can handle even the most difficult drive configurations another CONTI product creating new perspectives in today's drive technology.



CONTI-V MULTIRIB® Multiple V-Ribbed Belt in a washing machine

Construction

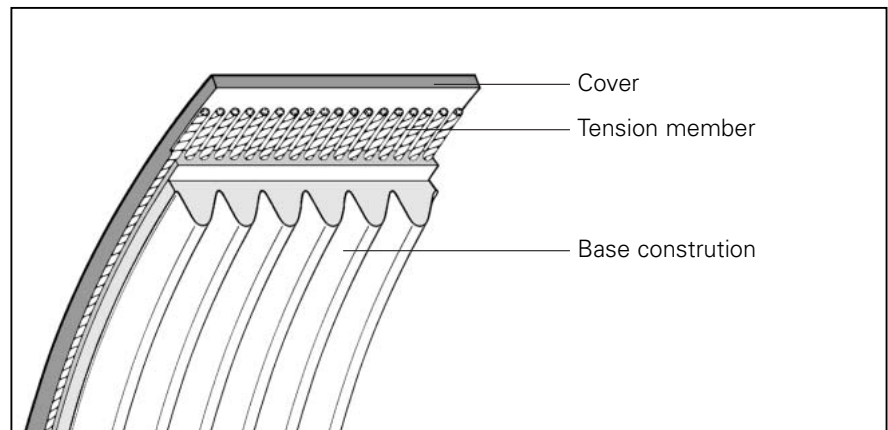

CONTI-V MULTIRIB® Multiple V-Ribbed Belts are made of first class materials and consist of the following three components:

- base construction
- tension member
- cover

Base construction

The base construction is made up of parallel V-shaped ribs in the direction of the belt travel. These ribs guarantee a good frictional engagement and ensure an even load distribution throughout the entire width of the belt. The polychloroprene-base elastomer is reinforced by transversely aligned fibres. It is hard wearing and virtually unaffected by ambient influences.

Tension member

The tension member consists of high-strength low-stretch polyester cords, which are continuously wound across the whole belt width, and encased in a special compound firmly bonded to the base construction.

Cover

The durable, flexible cover provides lasting protection of the tension member and permits the use of reverse-tensioning idlers.

Properties

High transmission ratio

The belt's construction ensures extremely high flexibility and consequently transmission ratios of up to 1:40 using pulleys of extremely small diameter.

High belt speed

Construction and materials allow high-speed drives with belt speeds of up to 60 m/s.

Compact drives

The outstanding flexibility permits a high reverse bending capacity at a belt flex frequency of up to 120 per second. This in turn means extremely small pulley diameters and allows counterflexing. Short centre distances and restricted spaces can be overcome by using reverse-tensioning idlers and serpentine drives.

High power transmission

Excellent frictional engagement and even load distribution across the entire belt width contribute to ensure an efficiency of 98%. For high power transmissions we can supply Multiple V-Ribbed Belts of the ZAR type which have aramid tension members. For lower power transmissions and high speed changes, CONTI-V MULTIRIB® Multiple V-Ribbed Belts can be used as V-flat drives.

Smooth running

No twisting in the pulley grooves due to the single belt design characteristics. This ensures low vibration and quiet operation.

Long service life

The tough, abrasion resistant materials can withstand high loading and dynamic stress. This assures long belt life and economical drives.

All standard **CONTI-V MULTIRIB® Multiple V-Ribbed Belts** are:

- designed for temperatures ranging from +80°C to -30°C
- resistant to certain oils
- unaffected by weathering
- resistant to effects of ozone
- suited to use in tropical climates
- electrically conductive

Designation

CONTI-V MULTIRIB® Multiple V-Ribbed Belts are fully specified by a coding system based on DIN 7867/ISO 9982 and showing the following data:

- number of ribs
- belt section
- effective length
- type

Examples

CONTI-V MULTIRIB® Multiple V-Ribbed Belts 6 PJ 1321/520 J 6

DIN/ISO designation 6 _____ number of ribs
PJ _____ belt section
1321 _____ effective length in mm

UK designation 520 _____ effective length in 1/10 inch
J _____ belt section
6 _____ number of ribs

CONTI-V MULTIRIB® Multiple V-Ribbed Belts 8 PL 2070/815 L 8 ZAR

DIN/ISO designation 8 _____ number of ribs
PL _____ belt section
2070 _____ effective length in mm

UK designation 815 _____ effective length in 1/10 inch
L _____ belt section
8 _____ number of ribs

Type designation ZAR _____ Type with aramid tension member

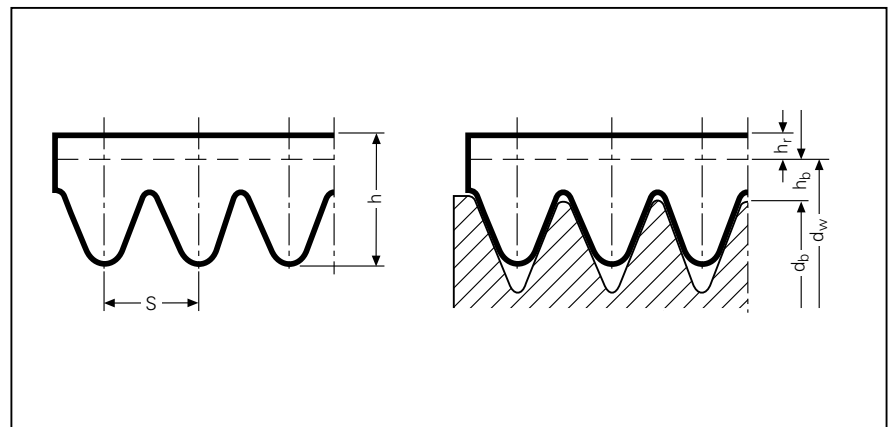
Available sizes

Belt section

Fig. 1

Characteristic sizes

Table 1

Section	DIN/ISO designation	PH	PJ	PK	PL	PM
Rib spacing s	mm	1.60	2.34	3.56	4.70	9.40
Belt height $h \approx$	mm	2.7	3.8	5.0	9.0/7.5*	14.5
Effective line differential h_b	mm	0.8	1.2	1.5	3.0	4.0
Back height h_r	mm	1.0	1.1	1.5	1.5	2.0
Minimum pulley diameter $d_{b \min}$	mm	13	20	45	75	180
Maximum belt speed v_{\max}	m/s	60	60	50	40	35
Weight per rib	kg/m	0.005	0.009	0.021	0.040/0.037*	0.120
Effective length range L_b	from mm	1140	356	527	991/2324*	2286
	to mm	1992	2489	2550	2235/6096*	16764

*Values for truncated profile.

Sections

CONTI-V MULTIRIB® Multiple V-Ribbed Belts comply with DIN and international standards.

Available sections and sizes are shown in the above table.

Lengths

CONTI-V MULTIRIB® Multiple V-Ribbed Belts are manufactured in graduated lengths, with successive lengths varying by small differences. The lengths are in compliance with international standards.

Available lengths are listed in Table 2.

Special types

CONTI-V MULTIRIB® Multiple V-Ribbed Belts are also available in the following special types:

ELAST elastic type for sections PH and PJ.

ZAR type with particularly high load carrying capacity. It has an aramid tension member. The belts are developed for use on commercially available standard pulleys.

Section PL available from 2019 mm length

Section PM available from 2268 mm length

The properties of standard CONTI-V MULTIRIB® Multiple V-Ribbed Belts are listed on page 6.

Standard lengths of CONTI-V MULTIRIB® Multiple V-Ribbed Belts

Table 2

Section PH*		Section PJ		Section PK		Section PL		Section PM	
Effective length L_b		Effective length L_b		Effective length L_b		Effective length L_b		Effective length L_b	
mm	1/10 inch	mm	1/10 inch	mm	1/10 inch	mm	1/10 inch	mm	1/10 inch
1580	622	356	140	527	207	991	390	2286	900
1600	630	381	150	630	248	1041	410	2388	940
1874	738	406	160	648	255	1149	452	2515	990
1890	744	432	170	698	275	1168	460	2693	1060
1915	754	457	180	730	287	1194	470	2832	1115
1930	760	483	190	770	303	1219	480	2921	1150
1951	768	508	200	810	319	1270	500	3010	1185
1980	780	559	220	830	327	1295	510	3124	1230
1992	784	584	230	880	346	1321	520	3327	1310
		610	240	920	362	1334	525	3531	1390
		660	260	960	378	1346	530	3734	1470
		686	270	1000	394	1372	540	4089	1610
		711	280	1035	407	1397	550	4191	1650
		737	290	1130	445	1422	560	4470	1760
		762	300	1205	474	1435	565	4648	1830
		787	310	1280	504	1473	580	5029	1980
		813	320	1314	517	1499	590	5410	2130
		838	330	1397	550	1562	615	6121	2410
		864	340	1420	559	1613	635	6883	2710
		889	350	1460	575	1651	650	7646	3010
		914	360	1480	583	1664	655	8408	3310
		965	380	1520	598	1715	675	9169	3610
		991	390	1549	610	1765	695	9931	3910
		1016	400	1610	634	1803	710	10693	4210
		1054	415	1645	648	1841	725	12217	4810
		1092	430	1664	655	1943	765	13741	5410
		1143	450	1725	679	1956	770	15266	6010
		1168	460	1843	726	1981	780	16764	6600
		1194	470	1885	742	2019	795		
		1219	480	1980	780	2070	815		
		1245	490	2031	800	2096	825		
		1270	500	2080	819	2134	840		
		1295	510	2164	852	2195	865		
		1321	520	2236	880	2235	880		
		1372	540	2550	1004	2324	915		
		1397	550			2362	930		
		1461	575			2477	975		
		1473	580			2515	990		
		1549	610			2705	1065		
		1600	630			2743	1080		
		1626	640			2845	1120		
		1651	650			2895	1140		
		1702	670			2921	1150		
		1753	690			2997	1180		
		1778	700			3085	1215		
		1854	730			3124	1230		
		1915	754			3289	1295		
		1930	760			3327	1310		
		1956	770			3492	1375		
		1981	780			3696	1455		
		2019	795			4051	1595		
		2083	820			4191	1650		
		2210	870			4470	1760		
		2286	900			4622	1820		
		2337	920			5029	1980		
		2489	980			5385	2120		
						6096	2400		

*on request

Futher lengths
on request

Length tolerances for CONTI-V MULTIRIB® Multiple V-Ribbed Belts

(measurements in mm)

Table 3

Profil PH		Profil PJ		Profil PK		Profil PL		Profil PM	
Effective length L_b	Tolerance	Effective length L_b	Tolerance	Effective length L_b	Tolerance	Effective length L_b	Tolerance	Effective length L_b	Tolerance
all lengths	±5	356–1500	±5	527–1000	±5	991–2000	±7	2286–3000	±15
		1501–2000	±7	1001–1500	±6	2001–2600	±10	3001–5000	±20
		2001–2500	±10	1501–2550	±8	2601–3000	±15	5001–6500	±30
						3001–5000	±20	6501–9000	±45
						5001–6100	±30	9001–13000	±60
								13001–16800	±90

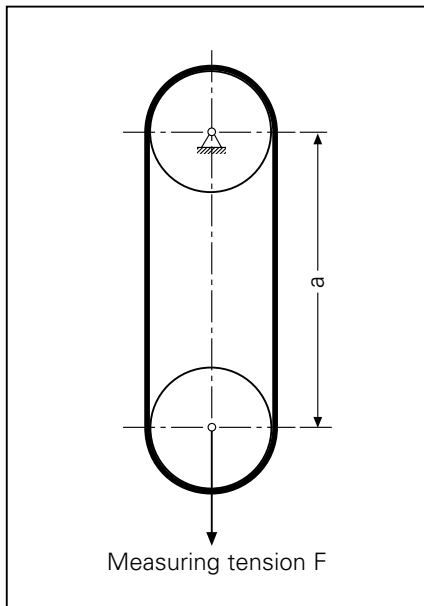

Length measurement

Fig. 2

Length measurement

The effective length is the length that is calculated using this catalogue and used to designate a CONTI-V MULTIRIB® Multiple V-Ribbed Belt.

The CONTI-V MULTIRIB® Multiple V-Ribbed Belt length is measured – as standardised in DIN 7867 – using two pulleys with the same diameter (see Fig. 2).

The effective circumference of the measuring pulleys as well as the measuring tension per rib are both shown in Table 4.

The effective length L_b is calculated from twice the centre distance "a" plus the effective circumference of the measuring pulley U_b .

$$L_b = 2 a + U_b$$

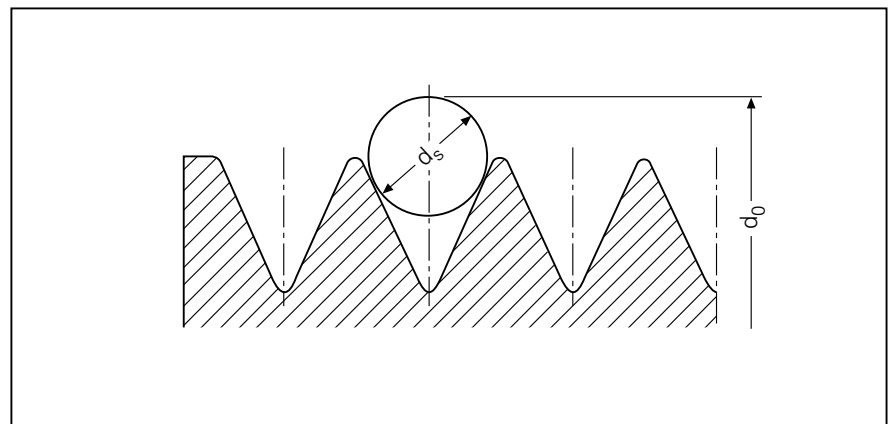

Measuring pulley

Fig. 3

Measuring pulleys and measuring tension

Table 4

Section		PH	PJ		PK	PL	PM
Effective length of belt	mm	all lengths	< 559	≥ 559	all lengths	all lengths	all lengths
Effective circumference U_b of pulley	mm	300	100	300	300	500	800
Diameter over rod $d_0 \pm 0.13$	mm	95.60	32.06	95.72	96.48	161.51	259.17
Rod diameter $d_s \pm 0.011$	mm	1.0	1.5	1.5	2.5	3.5	7.0
Measuring tension F per rib	N	30	50	50	100	200	450

Further information is given in Section 2 on "Multi-grooved pulleys", page 13

Selection

Tolerances

Sizes

Surface finish

Designation

Pulley types

Diameter

Taper bushes

Multi-grooved pulleys

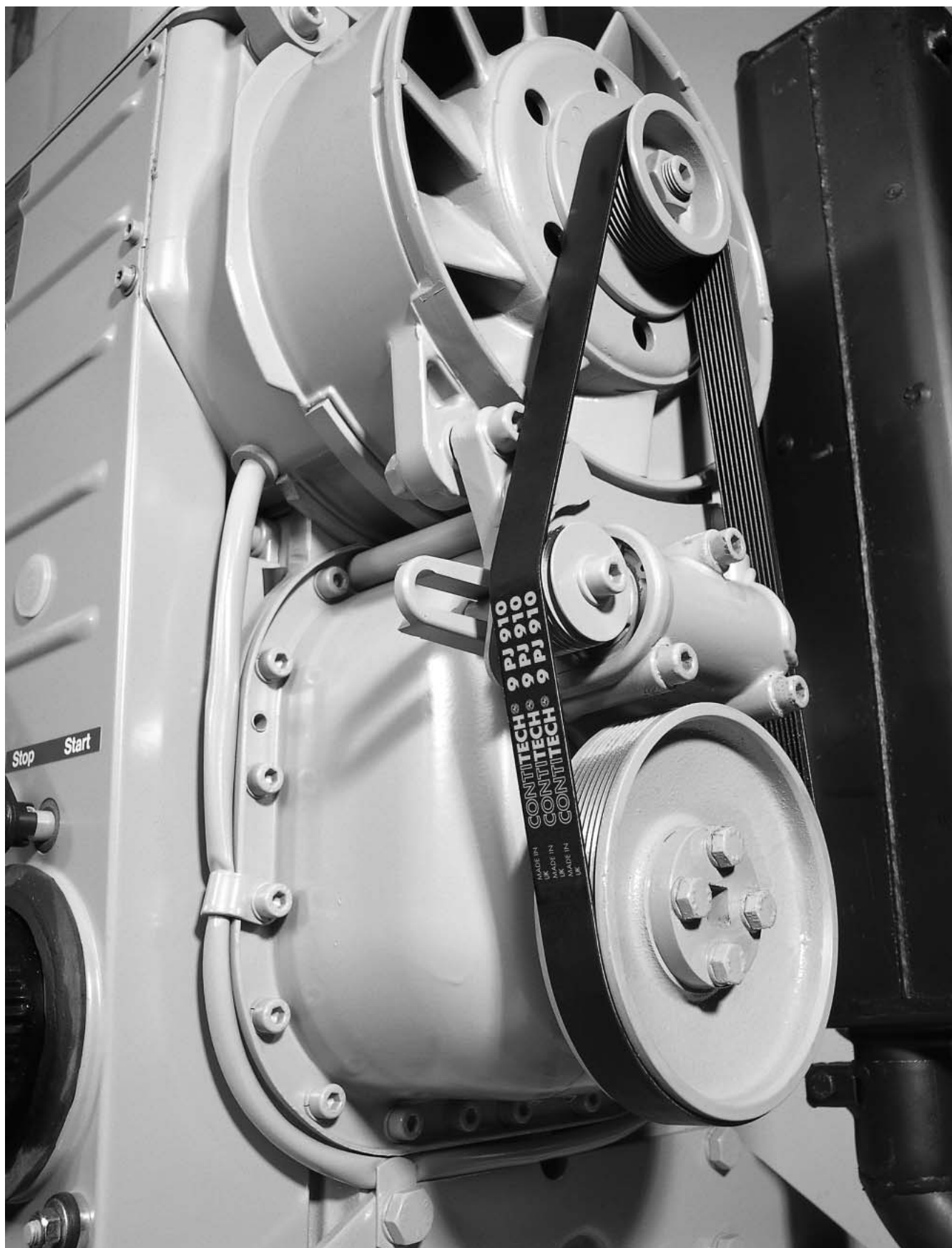

CONTI-V MULTIRIB® Multiple V-Ribbed Belt
on an internal combustion engine

Multi-grooved pulleys

The performance of a Multiple V-Ribbed Belt drive is affected to a large extent by the multi-grooved pulleys contained in the drive. Pulleys should be manufactured to DIN 7867/ISO 9982 specifications.

Multi-grooved pulleys are made of materials widely used in mechanical engineering, such as St 37 and steel of higher strength ratings, grey cast iron (e.g. GG 20) with no signs of bubbles or other surface irregularities, as well as aluminium alloys with coated surface.

Selection

- Only use recommended pulley diameters.
The effective diameter d_b of the small pulley is shown for each section size in the first column of the "Power capacity rating" tables on Pages 32 to 45. In general, the effective diameters have been selected according to the R-20 series.
- Never use below minimum pulley diameters.
Pulley diameters smaller than those recommended will shorten the belt's life and hence impair the economical and reliable operation of the drive.
- Try to select relatively large pulley diameters.
Large pulley diameters have a positive impact on the service life of the belt. However, care should be taken to ensure that the maximum belt speed is not exceeded. Drive economy factors should also be taken into consideration for each individual case. Where a high transmission ratio and low power are required, a flat pulley may also be used as the large pulley.

Pulleys in service

- Multigrooved pulleys must be clean and entirely free from burr. They are to be correctly aligned and installed parallel to the axis.
- Pulleys that are damaged – e.g. bent, worn or corroded – should be replaced without delay.

Further information is given in Section 5 on "Installation and storage of multiple V-Ribbed belts", Page 62.

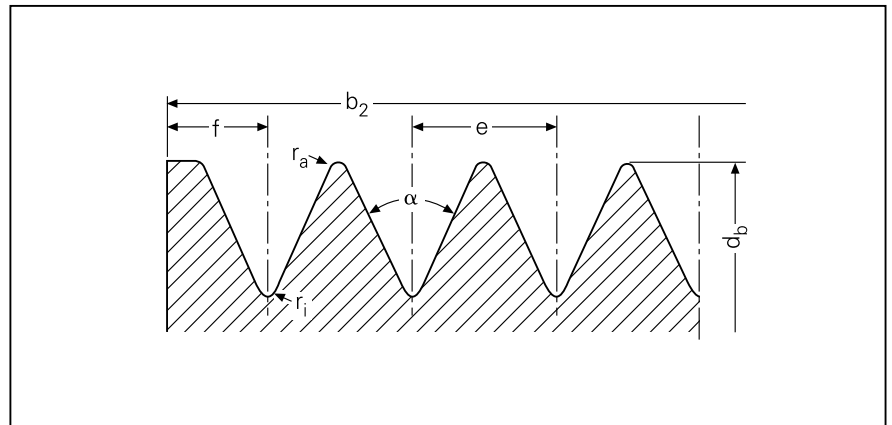
Sizes

Cross-section of pulley grooves

Fig. 4

Groove profiles and dimensions (dimensions in mm)

Table 5

Section acc.	DIN/ISO designation	PH	PJ	PK	PL	PM
Groove spacing e		1.60	2.34	3.56	4.70	9.40
Permissible deviation from e		±0.03	±0.03	±0.05	±0.05	±0.08
Sum of permissible deviations from e		±0.30	±0.30	±0.30	±0.30	±0.30
f_{\min}		1.3	1.8	2.5	3.3	6.4
Groove angle α	±0.5°	40°	40°	40°	40°	40°
Top radius $r_{a \min}$		0.15	0.20	0.25	0.40	0.75
Bottom radius $r_{i \max}$		0.30	0.40	0.50	0.40	0.75
Minimum effective diameter $d_{b \min}$		13	20	45	75	180
Minimum face width b_2 where number of grooves is z	3	5.8	8.28	12.12	16.0	31.6
	4	7.4	10.62	15.68	20.7	41.0
$b_2 = (z - 1) \cdot e + 2f$	5	9.0	12.96	19.24	25.4	50.4
	6	10.6	15.30	22.80	30.1	59.8
	7	12.2	17.64	26.36	34.8	69.2
	8	13.8	19.98	29.92	39.5	78.6
	9	15.4	22.32	33.48	44.2	88.0
	10	17.0	24.66	37.04	48.9	97.4

Fig. 4 is not a scale drawing, but for reference purposes only.
Full details are contained in DIN 7867/ISO 9982/BS 7620

Designation

Designation of multi-grooved pulleys to DIN 7867/ISO 9982 specifications shows the number of grooves, belt section and the effective diameter.

Example

Multigrooved pulley – P 6 PJ 100 1R

P _____ designation for multi-grooved pulleys

6 _____ number of grooves

PJ _____ belt section

100 _____ effective diameter in mm

1R _____ type of pulley

Diameters

d_b — effective diameter
 d_w — pitch diameter
 h_b — effective line differential

Effective diameter

The effective diameter d_b of a multigrooved pulley is the key factor when the length and design power of a drive are calculated.

Pitch diameter

The pitch diameter d_w is used to calculate the transmission ratio. It is the sum of the effective diameter d_b and twice the effective line differential h_b .

$$d_w = d_b + 2 h_b$$

The values h_b for the effective line differential are given in Table 6.

Effective line differential h_b

Table 6

Belt section	PH	PJ	PK	PL	PM
Effective line differential h_b mm	0.8	1.2	1.5	3.0	4.0

Tolerances

Tolerances for the effective diameter, radial and axial runout are specified in DIN 7867.

Permissible tolerance for the diameters

Table 7

Effective diameter d_b in mm	Tolerance mm
≤ 74	6 grooves or less; 0.10 plus 0.003 for each additional groove
$> 74-500$	10 grooves or less; 0.15 plus 0.005 for each additional groove
> 500	10 grooves or less; 0.25 plus 0.010 for each additional groove

Radial runout tolerance

Table 8

Effective diameter d_b mm	Tolerance in mm
≤ 74	0.13
$> 74-250$	0.25
> 250	$0.25 + 0.0004$ per mm effective diameter above 250

Axial runout tolerance

Axial runout tolerance may not exceed 0.002 mm per mm of effective diameter.

Surface finish

Surface texture of multigrooved pulleys should not exceed $R_z 16 \mu\text{m}$. A greater roughness index could shorten the service life of the belt.

Multi-grooved pulleys with taper bushes, standard range

For the sections PJ and PL the measurements of the most common types of pulleys with standard diameters and a standard number of grooves are shown in Tables 9 to 17. They also list the designations and bore diameters of corresponding taper bushes.

Tolerance of pilot bore in accordance with DIN 7157 H 7.

Dimensions of taper bushes are shown on page 19.

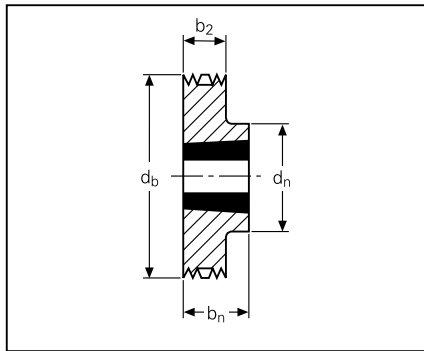

Type 1R

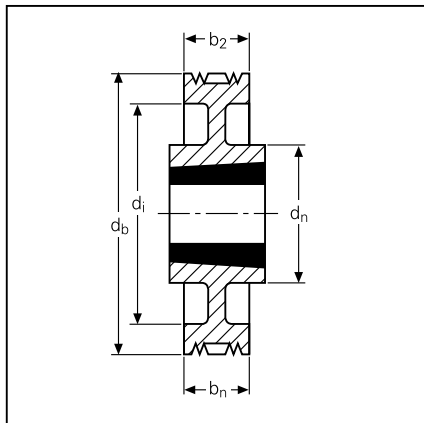

Type 6

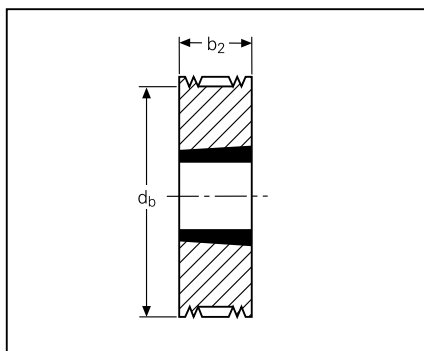

Type 2

Section PJ – With 4 grooves

Table 9

Face width 13.5 mm (measurements in mm)

Multi-grooved pulley					Taper bush			Pulley designation	Type
Effective Ø d _b	Pitch Ø d _w	Hub Ø d _n	Recess Ø d _i	Hub width b _n	Designation	Bore diameter max. d _{v max}	min. d _{v min}		
56	58.4	50	–	23	1108	24	10	P4PJ56–1108	1R
60	62.4	50	–	23	1108	24	10	P4PJ60–1108	1R
63	65.4	50	–	23	1108	24	10	P4PJ63–1108	1R
67	69.4	50	–	23	1108	24	10	P4PJ67–1108	1R
71	73.4	60	–	23	1108	24	10	P4PJ71–1108	1R
75	77.4	60	–	23	1108	24	10	P4PJ75–1108	1R
80	82.4	70	–	26	1310	32	14	P4PJ80–1310	1R
85	87.4	70	–	26	1310	32	14	P4PJ85–1310	1R
90	92.4	82	–	26	1610	38	14	P4PJ90–1610	1R
95	97.4	82	–	26	1610	38	14	P4PJ95–1610	1R
100	102.4	82	–	26	1610	38	14	P4PJ100–1610	1R
112	114.4	92	–	26	1610	38	14	P4PJ112–1610	1R
125	127.4	92	–	26	1610	38	14	P4PJ125–1610	1R
140	142.4	92	–	26	1610	38	14	P4PJ140–1610	1R
160	162.4	112	–	32	2012	48	19	P4PJ160–2012	1R
180	182.4	112	164	32	2012	48	19	P4PJ180–2012	6
200	202.4	112	184	32	2012	48	19	P4PJ200–2012	6
250	252.4	112	234	32	2012	48	19	P4PJ250–2012	6

Section PJ – With 8 grooves

Table 10

Face width 23 mm (measurements in mm)

Multi-grooved pulley					Taper bush			Pulley designation	Type
Effective Ø d _b	Pitch Ø d _w	Hub Ø d _n	Recess Ø d _i	Hub width b _n	Designation	Bore diameter max. d _{v max}	min. d _{v min}		
56	58.4	–	–	23	1108	24	10	P8PJ56–1108	2
60	62.4	–	–	23	1108	24	10	P8PJ60–1108	2
63	65.4	–	–	23	1108	24	10	P8PJ63–1108	2
67	69.4	–	–	23	1108	24	10	P8PJ67–1108	2
71	73.4	–	–	23	1108	24	10	P8PJ71–1108	2
75	77.4	–	–	23	1108	24	10	P8PJ75–1108	2
80	82.4	70	–	26	1310	32	14	P8PJ80–1310	1R
85	87.4	70	–	26	1310	32	14	P8PJ85–1310	1R
90	92.4	82	–	26	1610	38	14	P8PJ90–1610	1R
95	97.4	82	–	26	1610	38	14	P8PJ95–1610	1R
100	102.4	82	–	26	1610	38	14	P8PJ100–1610	1R
112	114.4	92	–	26	1610	38	14	P8PJ112–1610	1R
125	127.4	92	–	26	1610	38	14	P8PJ125–1610	1R
140	142.4	92	–	26	1610	38	14	P8PJ140–1610	1R
160	162.4	112	–	32	2012	48	19	P8PJ160–2012	1R
180	182.4	112	164	32	2012	48	19	P8PJ180–2012	6
200	202.4	112	184	32	2012	48	19	P8PJ200–2012	6
250	252.4	112	234	32	2012	48	19	P8PJ250–2012	6

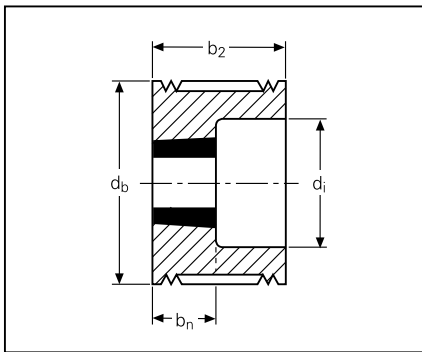

Type 3R

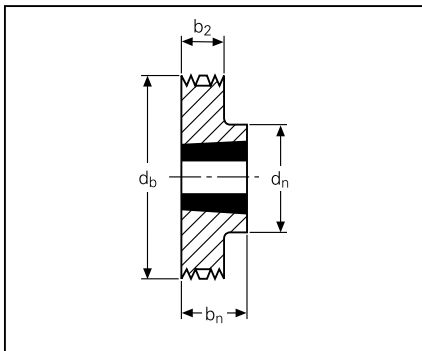

Type 1R

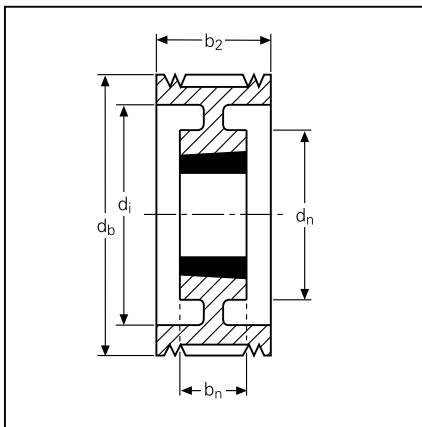

Type 5

Section PJ – With 12 grooves

Table 11

Face width 32.5 mm (measurements in mm)

Multi-grooved pulley					Taper bush			Pulley designation	Type
Effective Ø _{db}	Pitch Ø _{d_w}	Hub Ø _{d_n}	Recess Ø _{d_i}	Hub width _{b_n}	Designation	Bore diameter max. _{d_{v max}}	Bore diameter min. _{d_{v min}}		
67	69.4	–	51	23	1108	24	10	P12PJ67–1108	3R
71	73.4	–	55	23	1108	24	10	P12PJ71–1108	3R
75	77.4	–	59	26	1610	38	14	P12PJ75–1610	3R
80	82.4	–	64	26	1610	38	14	P12PJ80–1610	3R
85	87.4	–	69	26	1610	38	14	P12PJ85–1610	3R
90	92.4	–	74	26	1610	38	14	P12PJ90–1610	3R
95	97.4	–	79	26	1610	38	14	P12PJ95–1610	3R
100	102.4	–	82	26	1610	38	14	P12PJ100–1610	3R
112	114.4	–	94	26	1610	38	14	P12PJ112–1610	3R
125	127.4	–	105	32	2012	48	19	P12PJ125–2012	3R
140	142.4	124	–	45	2517	60	18	P12PJ140–2517	1R
160	162.4	124	–	45	2517	60	18	P12PJ160–2517	1R
180	182.4	124	160	45	2517	60	18	P12PJ180–2517	5
200	202.4	124	180	45	2517	60	18	P12PJ200–2517	5
250	252.4	124	230	45	2517	60	18	P12PJ250–2517	5

Section PJ – With 16 grooves

Table 12

Face width 42.0 mm (measurements in mm)

Multi-grooved pulley					Taper bush			Pulley designation	Type
Effective Ø _{db}	Pitch Ø _{d_w}	Hub Ø _{d_n}	Recess Ø _{d_i}	Hub width _{b_n}	Designation	Bore diameter max. _{d_{v max}}	Bore diameter min. _{d_{v min}}		
80	82.4	–	64	26	1610	38	14	P16PJ80–1610	3R
85	87.4	–	69	26	1610	38	14	P16PJ85–1610	3R
90	92.4	–	74	26	1610	38	14	P16PJ90–1610	3R
95	97.4	–	79	26	1610	38	14	P16PJ95–1610	3R
100	102.4	–	82	26	1610	38	14	P16PJ100–1610	3R
112	114.4	–	94	26	1610	38	14	P16PJ112–1610	3R
125	127.4	–	105	32	2012	48	19	P16PJ125–2012	3R
140	142.4	124	–	45	2517	60	18	P16PJ140–2517	1R
160	162.4	124	–	45	2517	60	18	P16PJ160–2517	1R
180	182.4	124	160	45	2517	60	18	P16PJ180–2517	5
200	202.4	124	180	45	2517	60	18	P16PJ200–2517	5
250	252.4	124	230	45	2517	60	18	P16PJ250–2517	5

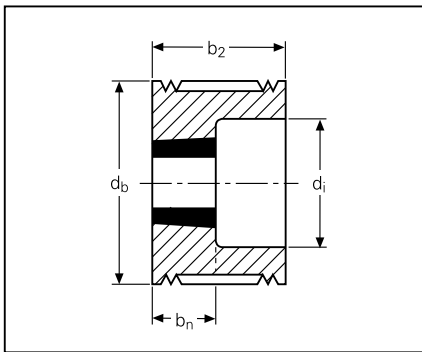

Type 3R

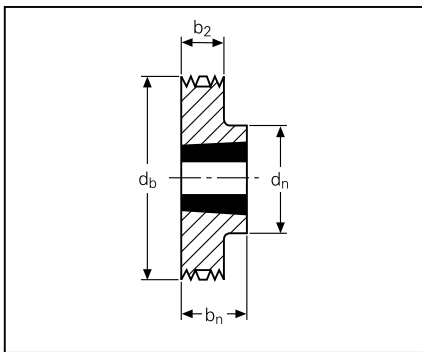

Type 1R

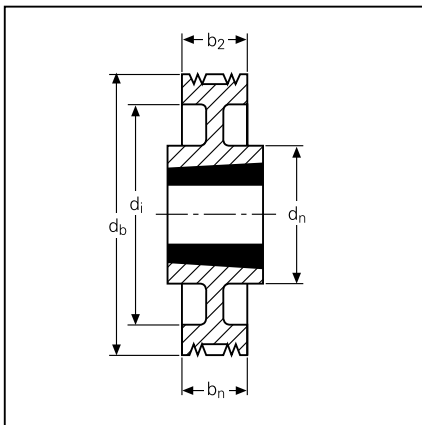

Type 6

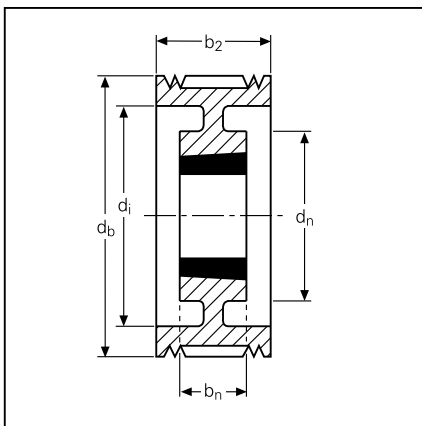

Type 5

Section PL – With 6 grooves

Table 13

Face width 38.5 mm (measurements in mm)

Multi-grooved pulley					Taper bush			Pulley designation	Type
Effective Ø _{db}	Pitch Ø _{d_w}	Hub Ø _{d_n}	Recess Ø _{d_i}	Hub width _{b_n}	Designation	Bore diameter max. _{d_v max}	Bore diameter min. _{d_v min}		
100	106	–	76	26	1610	38	14	P6PL100–1610	3R
106	112	–	82	26	1610	38	14	P6PL106–1610	3R
112	118	–	88	26	1610	38	14	P6PL112–1610	3R
118	124	–	94	32	2012	48	19	P6PL118–2012	3R
125	131	–	101	32	2012	48	19	P6PL125–2012	3R
132	138	–	108	32	2012	48	19	P6PL132–2012	3R
140	146	124	–	45	2517	60	18	P6PL140–2517	1R
150	156	124	–	45	2517	60	18	P6PL150–2517	1R
160	166	124	–	45	2517	60	18	P6PL160–2517	1R
170	176	124	–	45	2517	60	18	P6PL170–2517	1R
180	186	124	156	45	2517	60	18	P6PL180–2517	6
190	196	124	166	45	2517	60	18	P6PL190–2517	6
200	206	124	176	45	2517	60	18	P6PL200–2517	6
212	218	124	188	45	2517	60	18	P6PL212–2517	6
224	230	124	200	45	2517	60	18	P6PL224–2517	6
236	242	124	212	45	2517	60	18	P6PL236–2517	6
250	256	124	226	45	2517	60	18	P6PL250–2517	6
280	286	124	256	45	2517	60	18	P6PL280–2517	6
315	321	124	285	45	2517	60	18	P6PL315–2517	6
355	361	146	325	52	3020	75	35	P6PL355–3020	6
400	406	146	370	52	3020	75	35	P6PL400–3020	6
500	506	146	470	52	3020	75	35	P6PL500–3020	6
630	636	146	600	52	3020	75	35	P6PL630–3020	6
800	806	178	770	89	3535	85	48	P6PL800–3535	6

Section PL – With 8 grooves

Table 14

Face width 48.0 mm (measurements in mm)

Multi-grooved pulley					Taper bush			Pulley designation	Type
Effective Ø _{db}	Pitch Ø _{d_w}	Hub Ø _{d_n}	Recess Ø _{d_i}	Hub width _{b_n}	Designation	Bore diameter max. _{d_v max}	Bore diameter min. _{d_v min}		
100	106	–	76	26	1610	38	14	P8PL100–1610	3R
106	112	–	82	26	1610	38	14	P8PL106–1610	3R
112	118	–	88	26	1610	38	14	P8PL112–1610	3R
118	124	–	94	32	2012	48	19	P8PL118–2012	3R
125	131	–	101	32	2012	48	19	P8PL125–2012	3R
132	138	–	108	32	2012	48	19	P8PL132–2012	3R
140	146	–	116	45	2517	60	18	P8PL140–2517	3R
150	156	–	126	45	2517	60	18	P8PL150–2517	3R
160	166	–	136	45	2517	60	18	P8PL160–2517	3R
170	176	–	146	45	2517	60	18	P8PL170–2517	3R
180	186	124	156	45	2517	60	18	P8PL180–2517	5
190	196	124	166	45	2517	60	18	P8PL190–2517	5
200	206	124	176	45	2517	60	18	P8PL200–2517	5
212	218	124	188	45	2517	60	18	P8PL212–2517	5
224	230	124	200	45	2517	60	18	P8PL224–2517	5
236	242	124	212	45	2517	60	18	P8PL236–2517	5
250	256	124	226	45	2517	60	18	P8PL250–2517	5
280	286	146	256	52	3020	75	35	P8PL280–3020	6
315	321	146	285	52	3020	75	35	P8PL315–3020	6
355	361	146	325	52	3020	75	35	P8PL355–3020	6
400	406	146	370	52	3020	75	35	P8PL400–3020	6
500	506	146	470	52	3020	75	35	P8PL500–3020	6
630	636	146	600	52	3020	75	35	P8PL630–3020	6
800	806	178	770	89	3535	85	48	P8PL800–3535	6

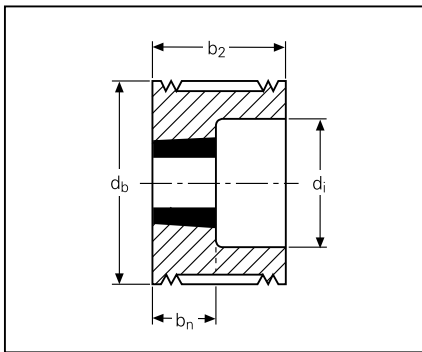

Type 3R

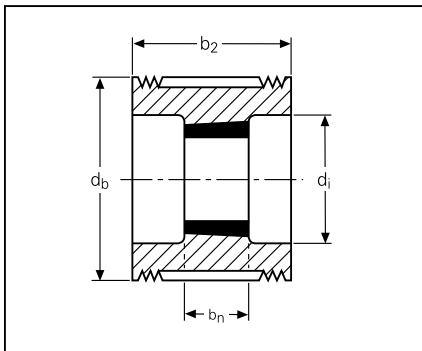

Type 10

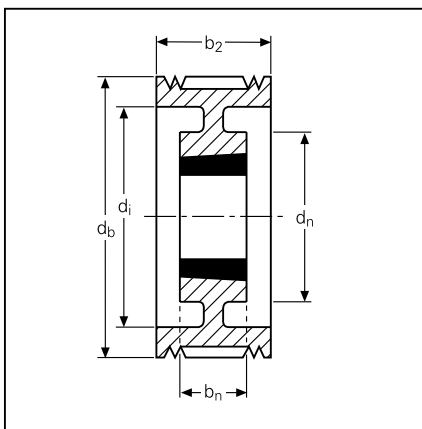

Type 5

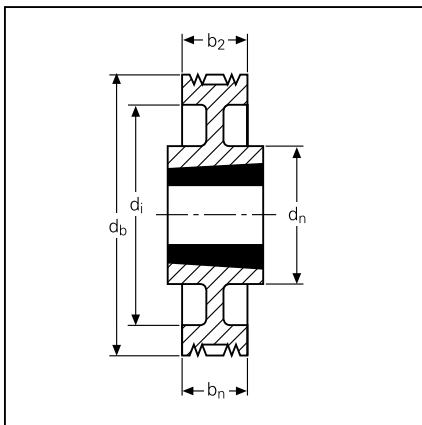

Type 6

Section PL – With 10 grooves

Table 15

Face width 57.0 mm (measurements in mm)

Multi-grooved pulley					Taper bush			Pulley designation	Type
Effective Ø _{db}	Pitch Ø _{d_w}	Hub Ø _{d_n}	Recess Ø _{d_i}	Hub width _{b_n}	Designation	Bore diameter max. _{d_{v max}}	Bore diameter min. _{d_{v min}}		
100	106	–	76	32	2012	48	19	P10PL100–2012	3R
106	112	–	82	32	2012	48	19	P10PL106–2012	3R
112	118	–	88	32	2012	48	19	P10PL112–2012	3R
118	124	–	94	45	2517	60	18	P10PL118–2517	10
125	131	–	101	45	2517	60	18	P10PL125–2517	10
132	138	–	108	45	2517	60	18	P10PL132–2517	10
140	146	–	116	45	2517	60	18	P10PL140–2517	10
150	156	–	126	45	2517	60	18	P10PL150–2517	10
160	166	–	136	45	2517	60	18	P10PL160–2517	10
170	176	–	146	45	2517	60	18	P10PL170–2517	10
180	186	124	156	45	2517	60	18	P10PL180–2517	5
190	196	124	166	45	2517	60	18	P10PL190–2517	5
200	206	146	176	52	3020	75	35	P10PL200–3020	5
212	218	146	188	52	3020	75	35	P10PL212–3020	5
224	230	146	200	52	3020	75	35	P10PL224–3020	5
236	242	146	212	52	3020	75	35	P10PL236–3020	5
250	256	146	226	52	3020	75	35	P10PL250–3020	5
280	286	146	256	52	3020	75	35	P10PL280–3020	5
315	321	178	285	89	3535	85	48	P10PL315–3535	6
355	361	178	325	89	3535	85	48	P10PL355–3535	6
400	406	178	370	89	3535	85	48	P10PL400–3535	6
500	506	178	470	89	3535	85	48	P10PL500–3535	6
630	636	178	600	89	3535	85	48	P10PL630–3535	6
800	806	216	770	102	4040	95	55	P10PL800–4040	6

Section PL – With 12 grooves

Table 16

Face width 67.0 mm (measurements in mm)

Multi-grooved pulley					Taper bush			Pulley designation	Type
Effective Ø _{db}	Pitch Ø _{d_w}	Hub Ø _{d_n}	Recess Ø _{d_i}	Hub width _{b_n}	Designation	Bore diameter max. _{d_{v max}}	Bore diameter min. _{d_{v min}}		
100	106	–	76	32	2012	48	19	P12PL100–2012	3R
106	112	–	82	32	2012	48	19	P12PL106–2012	3R
112	118	–	88	32	2012	48	19	P12PL112–2012	3R
118	124	–	94	45	2517	60	18	P12PL118–2517	10
125	131	–	101	45	2517	60	18	P12PL125–2517	10
132	138	–	108	45	2517	60	18	P12PL132–2517	10
140	146	–	116	45	2517	60	18	P12PL140–2517	10
150	156	–	126	45	2517	60	18	P12PL150–2517	10
160	166	–	136	45	2517	60	18	P12PL160–2517	10
170	176	–	146	45	2517	60	18	P12PL170–2517	10
180	186	–	156	45	2517	60	18	P12PL180–2517	10
190	196	124	166	45	2517	60	18	P12PL190–2517	5
200	206	146	176	52	3020	75	35	P12PL200–3020	5
212	218	146	188	52	3020	75	35	P12PL212–3020	5
224	230	146	200	52	3020	75	35	P12PL224–3020	5
236	242	146	212	52	3020	75	35	P12PL236–3020	5
250	256	146	226	52	3020	75	35	P12PL250–3020	5
280	286	146	256	52	3020	75	35	P12PL280–3020	5
315	321	178	285	89	3535	85	48	P12PL315–3535	6
355	361	178	325	89	3535	85	48	P12PL355–3535	6
400	406	178	370	89	3535	85	48	P12PL400–3535	6
500	506	178	470	89	3535	85	48	P12PL500–3535	6
630	636	178	600	89	3535	85	48	P12PL630–3535	6
800	806	216	770	102	4040	95	55	P12PL800–4040	6

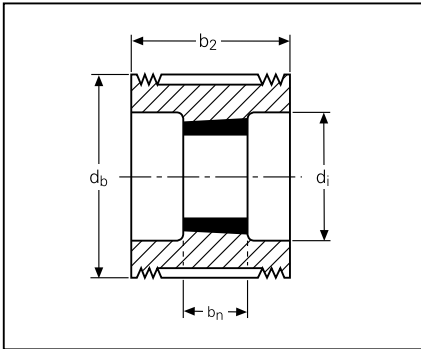

Type 10

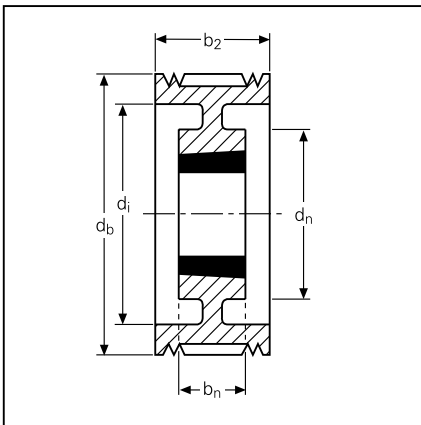

Type 5

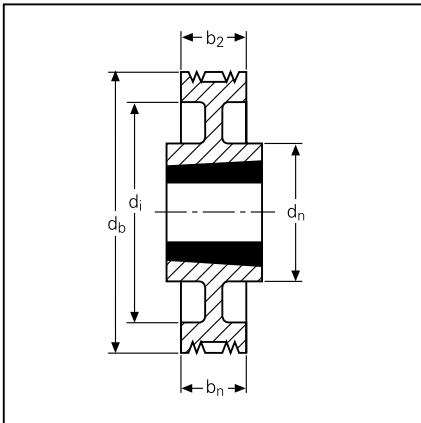

Type 6

Section PL – With 16 grooves

Table 17

Face width 86.0 mm (measurements in mm)

Multi-grooved pulley					Taper bush			Pulley designation	Type
Effective Ø _b	Pitch Ø _w	Hub Ø _n	Recess Ø _i	Hub width _n	Designation	Bore diameter max. d _{v max}	Bore diameter min. d _{v min}		
118	124	–	94	45	2517	60	18	P16PL118–2517	10
125	131	–	101	45	2517	60	18	P16PL125–2517	10
132	138	–	108	45	2517	60	18	P16PL132–2517	10
140	146	–	116	45	2517	60	18	P16PL140–2517	10
150	156	–	126	45	2517	60	18	P16PL150–2517	10
160	166	–	136	52	3020	75	35	P16PL160–3020	10
170	176	–	146	52	3020	75	35	P16PL170–3020	10
180	186	–	156	52	3020	75	35	P16PL180–3020	10
190	196	146	166	52	3020	75	35	P16PL190–3020	5
200	206	146	176	52	3020	75	35	P16PL200–3020	5
212	218	146	188	52	3020	75	35	P16PL212–3020	5
224	230	146	200	52	3020	75	35	P16PL224–3020	5
236	242	146	212	52	3020	75	35	P16PL236–3020	5
250	256	146	226	52	3020	75	35	P16PL250–3020	5
280	286	178	256	89	3535	85	48	P16PL280–3535	6
315	321	178	285	89	3535	85	48	P16PL315–3535	6
355	361	178	325	89	3535	85	48	P16PL355–3535	6
400	406	178	370	89	3535	85	48	P16PL400–3535	6
500	506	178	470	89	3535	85	48	P16PL500–3535	6
630	636	216	600	102	4040	95	55	P16PL630–4040	6
800	806	267	770	127	5050	125	70	P16PL800–5050	6

Taper bushes

Table 18

Designation and dimensions (measurements in mm)

Designation	Bore diameter														
	10	12	14	16	18	19	20	22	24	25*	28*				
1108															
1310	14	16	18	19	20	22	24	25	28	30	32	35*			
1610	14	16	18	19	20	22	24	25	28	30	32	35	38	40*	42*
1615	14	16	18	19	20	22	24	25	28	30	32	35	38	40*	42
2012	19	20	22	24	25	28	30	32	35	38	40	42	45	48	50
2517	24	25	28	30	32	35	38	40	42	45	48	50	55	60	
3020	30	32	35	38	40	42	45	48	50	55	60	65	70	75	
3535	48	50	55	60	65	70	75	80	85	90*					
4040	55	60	65	70	75	80	85	90	95	100*					
5050	70	75	80	85	90	95	100	125							

*denotes shallow keyway
Keyways to BS 4235

Glossary of symbols and terms

Drive calculation data

Examples of design procedure steps

ContiTech drive design service

Calculation of Multiple V-Ribbed Belt drives



CONTI-V MULTIRIB® Multiple V-Ribbed Belt
on a machine tool

Calculation of Multiple V-Ribbed Belt drives

The steps outlined on the following pages are used in designing drives fitted with CONTI-V MULTIRIB® Multiple V-Ribbed Belts and are in line with the internationally recognised design procedure for enclosed drives.

As so many factors influence belt performance, it is likely that designers of complicated and series drives will find it extremely helpful to consult ContiTech's Application Engineers for free advice, without any obligation whatsoever.

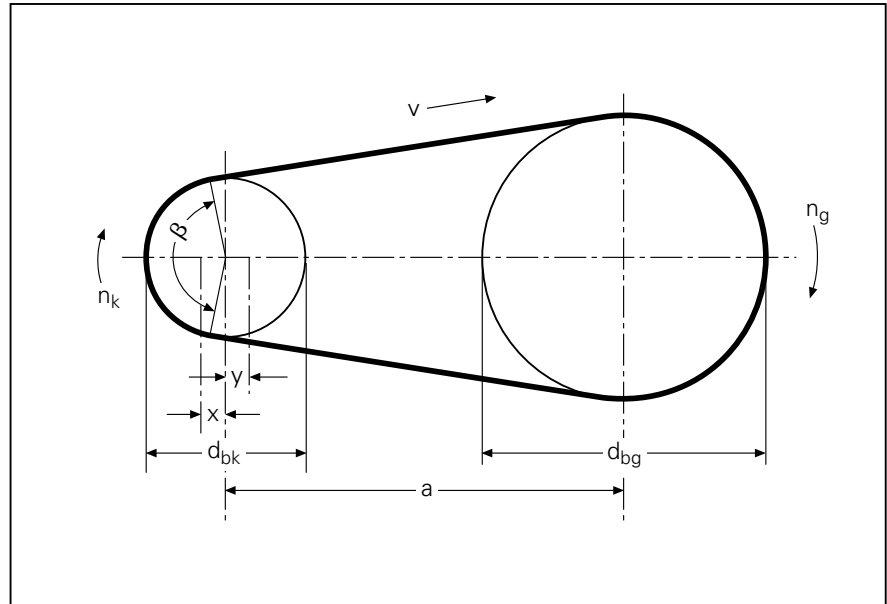

Glossary of symbols and terms

Symbol	Unit	Definition
a_{er}	mm	calculated centre distance
a_{max}	mm	maximum allowable centre distance
a_{min}	mm	minimum allowable centre distance
b_2	mm	face width of multi-rooved pulley
b_F	mm	width of flat pulley
c_1		power correction factor for arc of contact
c_{1F}		power correction factor for arc of contact for Multiple V-Ribbed Belt/flat pulley drives
c_2		service factor
c_{2er}		calculated service factor
c_3		length factor
d_a	mm	outside diameter of multi-grooved pulley
d_{aF}	mm	outside diameter of flat pulley
d_b	mm	effective diameter of multi-grooved pulley
d_{b1}	mm	effective diameter of driver pulley
d_{b2}	mm	effective diameter of driven pulley
d_{bg}	mm	effective diameter of large pulley
d_{bk}	mm	effective diameter of small pulley
d_{bF}	mm	effective diameter of flat pulley
d_w	mm	pitch diameter of multi-grooved pulley
d_{wF}	mm	pitch diameter of flat pulley
e	mm	groove spacing of multi-grooved pulley
f_B	s^{-1}	flex frequency

F	_____ N	static tension per rib
F_{ges}	_____ N	static tension per Multiple V-Ribbed Belt
F_e	_____ N	force applied to check installation tension per rib
F_{eges}	_____ N	force applied to check installation tension per Multiple V-Ribbed Belt
F_u	_____ N	effective pull
F_v	_____ N	total span tension
h_b	_____ mm	effective line differential
h_f	_____ mm	height factor
i	_____	transmission ratio
k	_____	number of pulleys in one drive
k_1	_____	installation tension factor
k_2	_____	centrifugal force factor
K_F	_____ mm	adjustment value for flat pulley diameter
L_b	_____ mm	effective length
L_f	_____ mm	free span length
n_1	_____ min^{-1}	rpm of driver pulley
n_2	_____ min^{-1}	rpm of driven pulley
n_g	_____ min^{-1}	rpm of large pulley
n_k	_____ min^{-1}	rpm of small pulley
P	_____ kW	power to be transmitted
P_B	_____ kW	design power
P_R	_____ kW	power capacity rating per rib
s	_____ mm	rib spacing on Multiple V-Ribbed Belt
t_e	_____ mm	deflection of the belt
v	_____ m/s	belt speed
x	_____ mm	take-up allowance for tensioning and retensioning the Multiple V-Ribbed Belt
y	_____ mm	installation allowance for easy fitting of the Multiple V-Ribbed Belt
z	_____	number of ribs
z_{er}	_____	calculated number of ribs
β	_____ ° (degrees)	arc of contact around the small pulley

Drive calculation data

The following pages contain all the necessary data, formulae and tables needed when designing a new drive fitted with a Multiple V-Ribbed Belt. Tables for values which can easily be calculated using the formulae provided have been omitted.

Power correction factor c_1 for arc of contact

Factor c_1 corrects the power rating P_R , which can be derived from the power capacity rating tables for an arc of contact $\beta \neq 180^\circ$ at the small pulley d_{bk} , for small arcs of contact.

Power correction factor c_1 for arc of contact

Table 19

Arc of contact β °(degrees)	Power correction factor c_1 for arc of contact	Arc of contact β °(degrees)	Power correction factor c_1 for arc of contact
201	1.04	142	0.90
198	1.04	139	0.89
195	1.03	136	0.87
192	1.03	133	0.87
189	1.02	130	0.86
186	1.01	127	0.85
183	1.01	123	0.83
180	1.00	120	0.82
177	0.99	117	0.81
174	0.99	113	0.79
171	0.98	109	0.78
169	0.97	106	0.76
166	0.97	103	0.75
163	0.96	100	0.74
160	0.95	96	0.72
157	0.94	92	0.69
154	0.93	88	0.67
151	0.92	84	0.66
148	0.92	80	0.64
145	0.91	77	0.62

Service factor c_2

The service factor c_2 is selected according to the operational hours per day and the type of driver and driven machine used. Additional service factors are required for unusual conditions, such as a high torque, variable speed drives, heavy shock or frequent stops and starts. When calculating these values, no account has been taken of particular design conditions, such as the use of tensioners.

In case of doubt, consult ContiTech's Application Engineers for advice.

Service factor c_2

Table 20

	Examples of driven machines	Operational hours per day			Operational hours per day		
		10 and less	Between 10 and 16	Over 16	10 and less	Between 10 and 16	Over 16
		Examples of drive motors AC and three-phase AC motors with normal torque (up to twice the rated torque) e.g. synchronous and single-phase motors with split-phase starting, three-phase AC motors with full-voltage, star-delta or slipring starter; DC motors, shunt wound; internal combustion engines and turbines with speeds of over 600 rpm		AC and three-phase AC motors with high torque (over twice the rated torque), e.g. single-phase motors with high torque; DC motors, series wound and compound wound; internal combustion engines and turbines with speeds of 600 rpm and less			
Light-duty drives	Domestic gadgets (kitchen appliances, washing machines, dryers), centrifugal pumps and compressors, belt conveyors (light load), fans and pumps up to 7.5 kW	1	1.1	1.2	1.1	1.2	1.3
Medium-duty drives	Sheet steel cutters, presses, chain and belt conveyors (heavy load), vibrating screens, generators, exciters, masticators, machine tools (lathes and grinders), laundry machinery, printing machinery, fans and pumps over 7.5 kW	1.1	1.2	1.3	1.2	1.3	1.4
Heavy-duty drives	Granulators, piston compressors, heavy-duty overshot loaders and reciprocating conveyors (screw conveyors, apron conveyors, bucked elevators, shovel loaders), elevators, briquetting presses, textile machinery, paper machinery, piston pumps, dredging pumps, reciprocating saws, hammer mills	1.2	1.3	1.4	1.4	1.5	1.6
Extra heavy-duty drives	Heavy-duty granulators, calenders, mixers, winches, cranes, excavators	1.3	1.4	1.5	1.5	1.6	1.8

Length factor c_3

The length factor c_3 takes into account the flex frequency as a function of Multiple V-Ribbed Belt length.

Length factor c_3

Table 21

CONTI-V MULTIRIB® Multiple V-Ribbed Belt Section PH																		
L_b mm	400	500	610	730	870	1020	1100	1200	1280	1320	1400	1550	1750	1900	2200	2500		
c_3	0.81	0.85	0.89	0.93	0.97	1.00	1.02	1.04	1.05	1.06	1.07	1.09	1.12	1.14	1.17	1.20		
CONTI-V MULTIRIB® Multiple V-Ribbed Belt Section PJ																		
L_b mm	356	406	483	610	723	864	1016	1105	1200	1280	1321	1397	1549	1752	1895	2210	2490	
c_3	0.78	0.81	0.85	0.89	0.93	0.97	1.00	1.02	1.04	1.05	1.06	1.07	1.09	1.12	1.14	1.17	1.20	
CONTI-V MULTIRIB® Multiple V-Ribbed Belt Section PK																		
L_b mm	550	698	755	812	855	900	955	1000	1050	1100	1150	1200	1300	1400	1500	1985	2100	2255
c_3	0.78	0.83	0.84	0.86	0.87	0.88	0.89	0.90	0.91	0.92	0.93	0.94	0.96	0.97	0.99	1.04	1.06	1.07
CONTI-V MULTIRIB® Multiple V-Ribbed Belt Section PL																		
L_b mm	1041	1270	1397	1562	1715	1841	1981	2095	2195	2325	2515	2745	2920	3125	3490	4050	4620	6095
c_3	0.86	0.89	0.91	0.94	0.96	0.97	0.99	1.00	1.01	1.02	1.04	1.06	1.07	1.09	1.11	1.15	1.18	1.24
CONTI-V MULTIRIB® Multiple V-Ribbed Belt Section PM																		
L_b mm	2285	2515	2695	2830	3010	3325	3530	4090	4470	4650	5030	6120	6885	7645	9170	10695	12215	16785
c_3	0.88	0.90	0.91	0.92	0.93	0.96	0.97	1.00	1.02	1.03	1.05	1.09	1.12	1.14	1.18	1.22	1.25	1.30

Choosing the section

The suitable section is chosen from Fig. 5 by locating the point at which the design power (power to be transmitted $P \cdot$ service factor c_2) intersects with the rpm of the small pulley. Each section takes up to 20 ribs into account. The width of the belt should not exceed the effective diameter of the small pulley.

In borderline cases, the next smaller section size should also be considered on the basis of the same pulley diameters. Experience has shown us that designers should avoid the minimum pulley diameter range.

Optimum power utilisation and drive economics are attained by selecting the largest possible pulley diameters. However, care must be taken to observe the maximum allowable belt speeds for each section size.

Choosing the section

Fig. 5

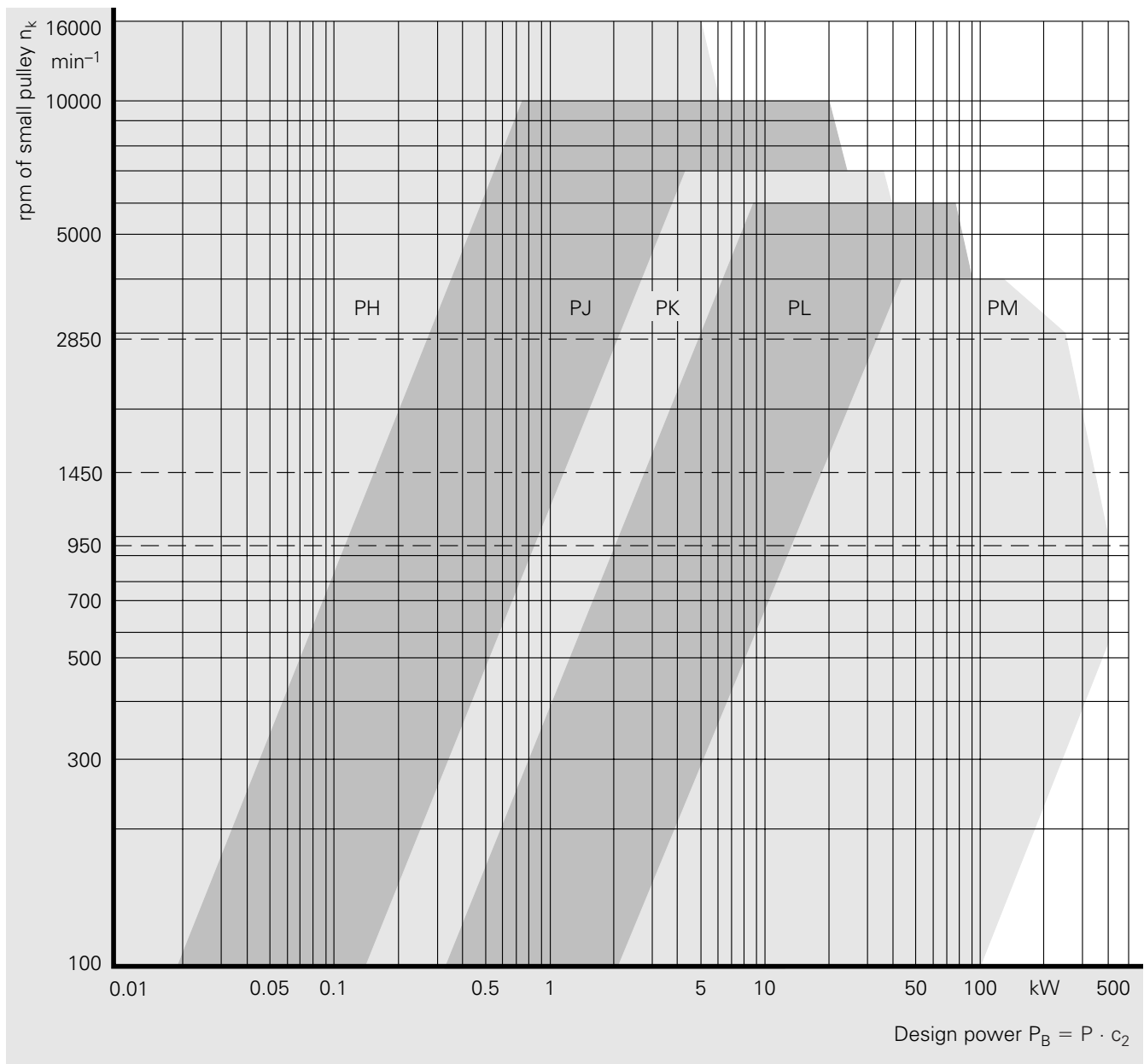

Transmission ratio i

Transmission ratio i is the ratio of rpm n_1 to n_2 or pitch diameter d_{w2} to d_{w1} .

$$i = \frac{n_1}{n_2} = \frac{d_{w2}}{d_{w1}} = \frac{d_{b2} + 2 \cdot h_b}{d_{b1} + 2 \cdot h_b}$$

This results in

$$d_{b1} = \frac{d_{b2}}{i} + 2 \cdot h_b \cdot \left(\frac{1}{i} - 1 \right) \text{ mm}$$

and

$$d_{b2} = d_{b1} \cdot i + 2 \cdot h_b \cdot (i - 1) \text{ mm}$$

n in min^{-1}

d_b in mm

h_b in mm from Table 1, page 7

Centre distance a

Centre distance a is calculated by the following approximation formula:

$$a \approx \frac{1}{4} \cdot \left(L_b - \frac{d_{bg} + d_{bk}}{2} \cdot \pi \right) + \frac{1}{4} \cdot \sqrt{\left(L_b - \frac{d_{bg} + d_{bk}}{2} \cdot \pi \right)^2 - 2 \cdot (d_{bg} - d_{bk})^2} \text{ mm}$$

The following applies if transmission ratio $i = 1:1$

$$a = \frac{L_b - \pi \cdot d_{bk}}{2} \text{ mm}$$

The following is recommended when determining the centre distance of a new drive design:

$$0.7 \cdot (d_{bg} + d_{bk}) \leq a \leq 2 \cdot (d_{bg} + d_{bk}) \text{ mm}$$

Deviations are possible to allow for specific drive requirements.

Effective length L_b

The effective length L_b can be approximated as following for a drive with two pulleys:

$$L_b \approx 2 \cdot a + \frac{\pi}{2} \cdot (d_{bg} + d_{bk}) + \frac{(d_{bg} - d_{bk})^2}{4 \cdot a} \text{ mm}$$

and is calculated precisely as follows:

$$L_b = 2 \cdot a \cdot \sin \frac{\beta}{2} + \frac{\pi}{2} \cdot (d_{bg} + d_{bk}) + \frac{\pi}{180} \cdot \left(90 - \frac{\beta}{2} \right) \cdot (d_{bg} - d_{bk}) \text{ mm}$$

Arc of contact β

The arc of contact β around the small pulley is:

$$\beta = 2 \cdot \arccos \left(\frac{d_{bg} - d_{bk}}{2 \cdot a} \right) \text{ }^\circ(\text{degrees})$$

The approximation formula for an arc contact $\beta > 110^\circ$ is:

$$\beta \approx 180 - 60 \cdot \left(\frac{d_{bg} - d_{bk}}{a} \right) \text{ }^\circ(\text{degrees})$$

Take-up and installation allowances x and y

Take-up allowance x is required for tensioning and retensioning the belt and installation allowance y is needed to ensure easy fitting of the belt.

Take-up allowance x for Multiple V-Ribbed Belts is

$$x = \frac{0.01 \cdot L_b}{\sin \frac{\beta}{2}} \text{ mm} \quad \text{for } L_b \leq 700 \text{ mm}$$

$$x = \frac{0.008 \cdot L_b}{\sin \frac{\beta}{2}} \text{ mm} \quad \text{for } L_b > 700 \text{ mm}$$

Installation allowance y for Multiple V-Ribbed Belts is

$$y = \frac{0.01 \cdot L_b + \pi \cdot h_f \cdot \frac{\beta}{360}}{\sin \frac{\beta}{2}} \text{ mm} \quad \text{for } L_b \leq 700 \text{ mm}$$

$$y = \frac{0.005 \cdot L_b + \pi \cdot h_f \cdot \frac{\beta}{360}}{\sin \frac{\beta}{2}} \text{ mm} \quad \text{for } L_b > 700 \text{ mm}$$

h_f = height factor in mm

Height factor h_f

Table 22

Belt section	PH	PJ	PK	PL	PM
height factor h_f	1.5	2.5	3	6	11

Belt speed v

Belt speed v is obtained from the diameter d_b and the rpm n of the belt pulley.

$$v = \pi \cdot \frac{(d_b + 2 \cdot h_b)}{60 \cdot 10^3} \cdot n \text{ m/s}$$

v in m/s

d_b in mm

h_b in mm from Table 1, page 7

n in min^{-1}

Ensure compliance with the recommended belt speeds for the various section sizes (see under Characteristic data, Table 1, page 7).

Flex frequency f_B

The flex frequency f_B is calculated from the belt speed v , the number of pulleys k , the effective length L_b and the effective line differential h_b .

$$f_B = \frac{10^3 \cdot v \cdot k}{L_b + 2 \cdot \pi \cdot h_b} \text{ s}^{-1}$$

f_B in s^{-1}

v in m/s

L_b in mm

h_b in mm

Number of ribs z

The number of ribs z derived from the power to be transmitted P and the factors c_1 , c_2 und c_3 .

$$z_{er} = \frac{P \cdot c_2}{P_R \cdot c_1 \cdot c_3}$$

The number of ribs z actually used is generally determined by rounding up z_{er} to the next whole number.

When rounding up, make shure that the service factor c_2 is still sufficient.

If in doubt, consult ContiTech's Application Engineers.

Total span tension F_v

The total span tension F_v is, as with all friction transmission drives, a decisive factor affecting the performance and service life of a Multiple V-Ribbed Belt drive.

- Insufficient installation tension results in inadequate power transmission, reduced efficiency and premature damage to the belt due to slip.
- Excessive installation tension leads to high specific surface pressure, increased flexing stress, increased strain on the load-bearing element and consequently premature cracking as well as belt stretch. Excessive installation tension is also a common cause of damage to shaft bearings.

For this reason, the initial tension required for the specific loads imposed on the belt must be determined and adhered to as closely as possible on installation.

The installation tension required for two-pulley drives can be calculated as follows:

$$F_v = (k_1 \cdot F_u + 2 \cdot k_2 \cdot v^2 \cdot z) \cdot \sin \frac{\beta}{2} \text{ N}$$

whereby:

$$F_u = \frac{P \cdot 10^3}{v} \text{ N} \quad \text{for } P \text{ in kW}$$

with z standing for the number of ribs.

Installation tension factor k_1 is used according to the service conditions concerned (Table 23, page 30).

Table 24 on page 30 shows the centrifugal force factor k_2 for each section size.

Installation tension factor k_1

Table 23

β ° (degrees)	Service conditions		
	Light-duty drives, constant load	Medium load	Heavy-duty drives shock loading, frequent stops and starts
180	1.50	1.70	1.90
175	1.53	1.73	1.93
170	1.56	1.76	1.96
165	1.59	1.79	1.99
160	1.63	1.83	2.03
155	1.67	1.87	2.07
150	1.71	1.91	2.11
145	1.75	1.95	2.15
140	1.80	2.00	2.20
135	1.85	2.05	2.25
130	1.91	2.11	2.31
125	1.97	2.17	2.37
120	2.04	2.24	2.44
115	2.11	2.31	2.51
110	2.19	2.39	2.59
105	2.28	2.48	2.68
100	2.38	2.58	2.78
95	2.49	2.69	2.89
90	2.62	2.82	3.02

Centrifugal force factor k_2

Table 24

Section code	PH	PJ	PK	PL	PM
Centrifugal force factor k_2	0.005	0.009	0.021	0.040/0.037*	0.120

*Values for truncated type.

The static tension F per rib must be determined prior to adjusting the installation tension to the Multiple V-Ribbed Belt.

$$F = \frac{F_v}{2 \cdot z \cdot \sin \frac{\beta}{2}} \text{ N}$$

Checking the static tension

Adjustment to the calculated static tension F can be made according to the diagrams in Fig. 7 and 8. Instructions are provided in the example of a two-pulley drive on page 46.

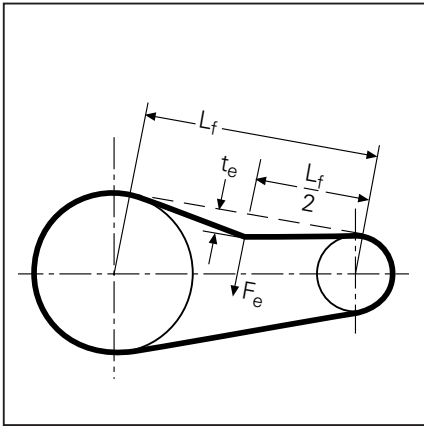

Deflection of belt t_e Fig. 6

F_e — force applied in N per rib

t_e — deflection in mm

L_f — span length in mm

$$t_e = \frac{L_f}{100} \cdot \text{installation tension value}$$

Installation tension graphs for
CONTI-V MULTIRIB® Multiple V-Ribbed Belts
Sections PH, PJ, PK

Fig. 7

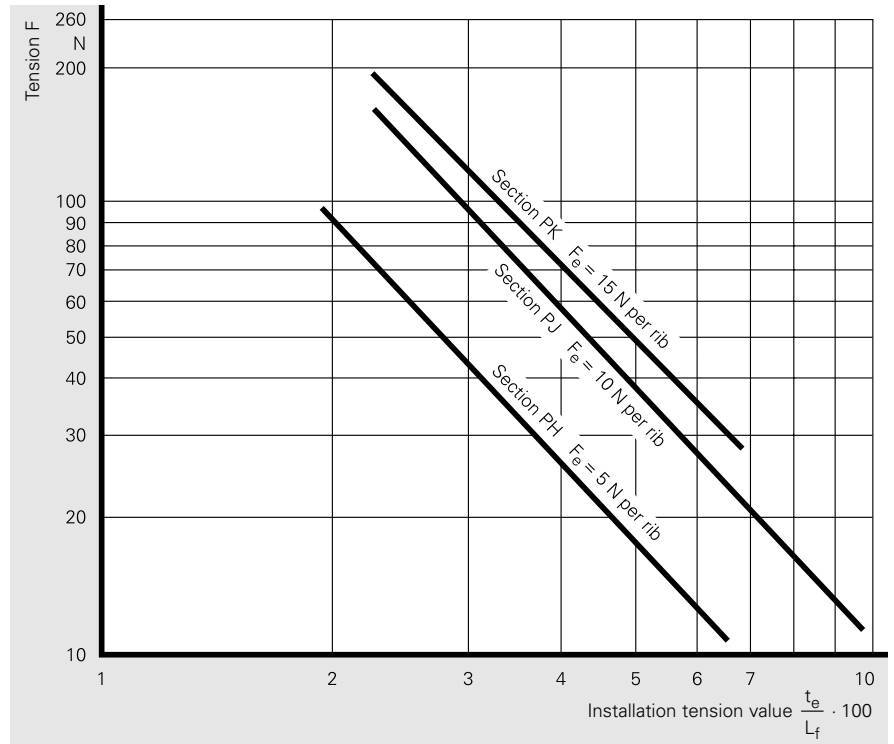

Section PL, PM

Fig. 8

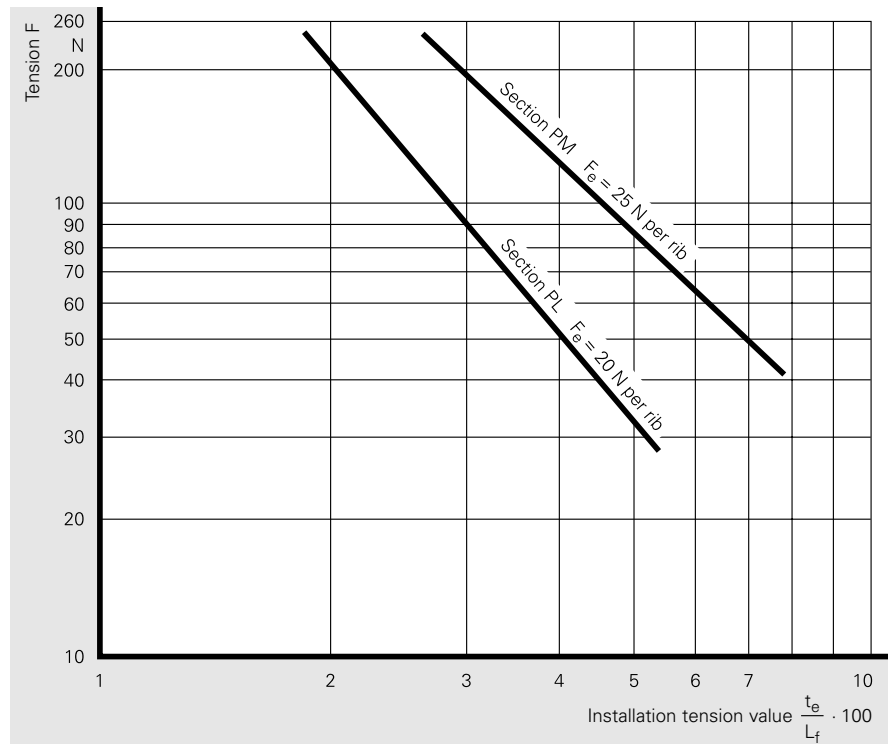

Power capacity rating P_R for CONTI-V MULTIRIB® Belt – section PH

Power capacity rating P_R (kW) for one rib as a function of the effective diameter of the small pulley d_{bk} , the transmission ratio i , the rpm of the small pulley n_k and the effective length $L_b = 1020$ mm.

Power capacity rating P_R for CONTI-V MULTIRIB® Belt – Section PH

Table 25

d_{bk} mm	i or 1:i	Rpm of the small pulley n_k (min ⁻¹)																	
		200	400	700	950	1200	1450	2000	2850	3500	5000	6000	7000	8000	9000	10000	12000	14000	16000
13	1.00	0.00	0.01	0.01	0.01	0.02	0.02	0.02	0.03	0.03	0.04	0.05	0.06	0.06	0.07	0.07	0.08	0.08	
	1.05	0.00	0.01	0.01	0.01	0.02	0.02	0.02	0.03	0.04	0.05	0.05	0.06	0.06	0.07	0.07	0.08	0.09	
	1.20	0.00	0.01	0.01	0.01	0.02	0.02	0.03	0.03	0.04	0.05	0.06	0.07	0.07	0.08	0.08	0.09	0.10	
	1.50	0.00	0.01	0.01	0.02	0.02	0.02	0.03	0.04	0.04	0.06	0.06	0.07	0.08	0.08	0.09	0.10	0.11	
	3.00	0.00	0.01	0.01	0.02	0.02	0.02	0.03	0.04	0.05	0.06	0.07	0.08	0.08	0.09	0.10	0.11	0.12	
15	1.00	0.01	0.01	0.01	0.02	0.02	0.03	0.03	0.04	0.05	0.06	0.07	0.08	0.09	0.10	0.10	0.12	0.13	
	1.05	0.01	0.01	0.01	0.02	0.02	0.03	0.03	0.04	0.05	0.07	0.08	0.09	0.09	0.10	0.11	0.12	0.13	
	1.20	0.01	0.01	0.02	0.02	0.02	0.03	0.04	0.05	0.05	0.07	0.08	0.09	0.10	0.11	0.12	0.14	0.15	
	1.50	0.01	0.01	0.02	0.02	0.02	0.03	0.04	0.05	0.06	0.08	0.09	0.10	0.11	0.12	0.13	0.14	0.16	
	3.00	0.01	0.01	0.02	0.02	0.03	0.03	0.04	0.05	0.06	0.08	0.09	0.10	0.11	0.12	0.13	0.15	0.17	
17	1.00	0.01	0.01	0.02	0.02	0.03	0.03	0.04	0.05	0.06	0.08	0.10	0.11	0.12	0.13	0.14	0.16	0.18	
	1.05	0.01	0.01	0.02	0.02	0.03	0.03	0.04	0.06	0.07	0.09	0.10	0.11	0.12	0.14	0.15	0.17	0.18	
	1.20	0.01	0.01	0.02	0.02	0.03	0.03	0.04	0.06	0.07	0.09	0.11	0.12	0.13	0.14	0.16	0.18	0.20	
	1.50	0.01	0.01	0.02	0.02	0.03	0.04	0.05	0.06	0.07	0.10	0.11	0.13	0.14	0.15	0.16	0.19	0.21	
	3.00	0.01	0.01	0.02	0.03	0.03	0.04	0.05	0.06	0.07	0.10	0.11	0.13	0.14	0.16	0.17	0.19	0.22	
20	1.00	0.01	0.01	0.02	0.03	0.04	0.04	0.05	0.07	0.09	0.11	0.13	0.15	0.16	0.18	0.19	0.22	0.24	
	1.50	0.01	0.01	0.02	0.03	0.04	0.04	0.05	0.07	0.09	0.12	0.13	0.15	0.17	0.18	0.20	0.23	0.25	
	1.20	0.01	0.01	0.02	0.03	0.04	0.04	0.06	0.08	0.09	0.12	0.14	0.16	0.18	0.19	0.21	0.24	0.27	
	1.50	0.01	0.01	0.02	0.03	0.04	0.04	0.06	0.08	0.09	0.13	0.15	0.16	0.18	0.20	0.22	0.25	0.28	
	3.00	0.01	0.02	0.02	0.03	0.04	0.05	0.06	0.08	0.10	0.13	0.15	0.17	0.19	0.21	0.22	0.26	0.30	
22.5	1.00	0.01	0.02	0.03	0.03	0.04	0.05	0.06	0.09	0.10	0.14	0.16	0.18	0.20	0.22	0.24	0.27	0.30	
	1.05	0.01	0.02	0.03	0.03	0.04	0.05	0.07	0.09	0.10	0.14	0.16	0.18	0.21	0.22	0.24	0.28	0.31	
	1.20	0.01	0.02	0.03	0.04	0.04	0.05	0.07	0.09	0.11	0.15	0.17	0.19	0.21	0.23	0.25	0.29	0.32	
	1.50	0.01	0.02	0.03	0.04	0.04	0.05	0.07	0.09	0.11	0.15	0.17	0.20	0.22	0.24	0.26	0.30	0.33	
	3.00	0.01	0.02	0.03	0.04	0.05	0.05	0.07	0.10	0.11	0.15	0.18	0.20	0.22	0.25	0.27	0.31	0.34	
25	1.00	0.01	0.02	0.03	0.04	0.05	0.06	0.08	0.10	0.12	0.16	0.19	0.21	0.24	0.26	0.28	0.32	0.35	
	1.05	0.01	0.02	0.03	0.04	0.05	0.06	0.08	0.10	0.12	0.16	0.19	0.22	0.24	0.26	0.29	0.32	0.36	
	1.20	0.01	0.02	0.03	0.04	0.05	0.06	0.08	0.11	0.13	0.17	0.20	0.22	0.25	0.27	0.30	0.34	0.37	
	1.50	0.01	0.02	0.03	0.04	0.05	0.06	0.08	0.11	0.13	0.17	0.20	0.23	0.25	0.28	0.30	0.35	0.38	
	3.00	0.01	0.02	0.03	0.04	0.05	0.06	0.08	0.11	0.13	0.18	0.21	0.23	0.26	0.28	0.31	0.35	0.39	
28	1.00	0.01	0.02	0.04	0.05	0.06	0.07	0.09	0.12	0.14	0.19	0.22	0.25	0.28	0.30	0.33	0.37	0.41	
	1.05	0.01	0.02	0.04	0.05	0.06	0.07	0.09	0.12	0.14	0.19	0.22	0.25	0.28	0.31	0.33	0.38	0.42	
	1.20	0.01	0.02	0.04	0.05	0.06	0.07	0.09	0.12	0.15	0.20	0.23	0.26	0.29	0.32	0.34	0.39	0.43	
	1.50	0.01	0.02	0.04	0.05	0.06	0.07	0.09	0.13	0.15	0.20	0.23	0.27	0.30	0.33	0.35	0.40	0.44	
	3.00	0.01	0.02	0.04	0.05	0.06	0.07	0.09	0.13	0.15	0.20	0.24	0.27	0.30	0.33	0.36	0.41	0.45	
31.5	1.00	0.01	0.03	0.04	0.05	0.07	0.08	0.10	0.14	0.16	0.22	0.26	0.29	0.33	0.36	0.38	0.44	0.48	
	1.05	0.01	0.03	0.04	0.05	0.07	0.08	0.10	0.14	0.17	0.23	0.26	0.30	0.33	0.36	0.39	0.44	0.48	
	1.20	0.01	0.03	0.04	0.05	0.07	0.08	0.11	0.14	0.17	0.23	0.27	0.30	0.34	0.37	0.40	0.45	0.50	
	1.50	0.01	0.03	0.04	0.06	0.07	0.08	0.11	0.14	0.17	0.23	0.27	0.31	0.34	0.38	0.41	0.46	0.51	
	3.00	0.01	0.03	0.04	0.06	0.07	0.08	0.11	0.15	0.17	0.24	0.28	0.31	0.35	0.38	0.41	0.47	0.52	
35.5	1.00	0.02	0.03	0.05	0.06	0.08	0.09	0.12	0.16	0.19	0.26	0.30	0.34	0.38	0.41	0.45	0.50	0.55	
	1.05	0.02	0.03	0.05	0.06	0.08	0.09	0.12	0.16	0.19	0.26	0.30	0.34	0.38	0.42	0.45	0.51	0.55	
	1.20	0.02	0.03	0.05	0.06	0.08	0.09	0.12	0.17	0.20	0.27	0.31	0.35	0.39	0.43	0.46	0.52	0.57	
	1.50	0.02	0.03	0.05	0.06	0.08	0.09	0.12	0.17	0.20	0.27	0.32	0.36	0.40	0.43	0.47	0.53	0.58	
	3.00	0.02	0.03	0.05	0.06	0.08	0.09	0.12	0.17	0.20	0.27	0.32	0.36	0.40	0.44	0.47	0.54	0.59	
40	1.00	0.02	0.03	0.05	0.07	0.09	0.10	0.14	0.19	0.22	0.30	0.35	0.39	0.44	0.47	0.51	0.57	0.61	
	1.05	0.02	0.03	0.05	0.07	0.09	0.10	0.14	0.19	0.22	0.30	0.35	0.40	0.44	0.48	0.51	0.58	0.62	
	1.20	0.02	0.03	0.06	0.07	0.09	0.11	0.14	0.19	0.23	0.31	0.36	0.40	0.45	0.49	0.52	0.59	0.63	
	1.50	0.02	0.03	0.06	0.07	0.09	0.11	0.14	0.19	0.23	0.31	0.36	0.41	0.45	0.49	0.53	0.60	0.64	
	3.00	0.02	0.03	0.06	0.07	0.09	0.11	0.14	0.19	0.23	0.31	0.36	0.41	0.46	0.50	0.54	0.60	0.65	
45	1.00	0.02	0.04	0.06	0.08	0.10	0.12	0.16	0.21	0.25	0.34	0.40	0.45	0.50	0.54	0.58	0.64	0.67	
	1.05	0.02	0.04	0.06	0.08	0.10	0.12	0.16	0.21	0.26	0.35	0.40	0.45	0.50	0.54	0.58	0.64	0.68	
	1.20	0.02	0.04	0.06	0.08	0.10	0.12	0.16	0.22	0.26	0.35	0.41	0.46	0.51	0.55	0.59	0.65	0.70	
	1.50	0.02	0.04	0.06	0.08	0.10	0.12	0.16	0.22	0.26	0.35	0.41	0.46	0.51	0.56	0.60	0.66	0.71	
	3.00	0.02	0.04	0.06	0.08	0.10	0.12	0.16	0.22	0.26	0.36	0.41	0.47	0.52	0.56	0.60	0.67	0.71	
50	1.00	0.02	0.04	0.07	0.09	0.11	0.13	0.18	0.24	0.29	0.39	0.45	0.50	0.55	0.60	0.64	0.69	0.72	
	1.05	0.02	0.04	0.07	0.09	0.11	0.13	0.18	0.24	0.29	0.39	0.45	0.51	0.56	0.60	0.64	0.70	0.73	
	1.20	0.02	0.04	0.07	0.09	0.11	0.13	0.18	0.24	0.29	0.39	0.46	0.51	0.56	0.61	0.65	0.71	0.74	
	1.50	0.02	0.04	0.07	0.09	0.12	0.14	0.18	0.25	0.29	0.40	0.46	0.52	0.57	0.62	0.66	0.72	0.75	
	3.00	0.02	0.04	0.07	0.09	0.12	0.14	0.18	0.25	0.30	0.40	0.46	0.52	0.58	0.62	0.67	0.73	0.76	
v_{max}	m/s																		

Power capacity rating P_R for CONTI-V MULTIRIB® Belt – Section PH

Table 25

d_{bk} mm	i or 1:i	Rpm of the small pulley n_k (min ⁻¹)																		
		200	400	700	950	1200	1450	2000	2850	3500	5000	6000	7000	8000	9000	10000	12000	14000	16000	
56	1.00	0.03	0.05	0.08	0.10	0.13	0.15	0.20	0.27	0.32	0.44	0.50	0.56	0.62	0.66	0.70	0.75	0.76	0.72	
	1.05	0.03	0.05	0.08	0.10	0.13	0.15	0.20	0.27	0.33	0.44	0.51	0.57	0.62	0.67	0.71	0.76	0.76	0.72	
	1.20	0.03	0.05	0.08	0.10	0.13	0.15	0.20	0.28	0.33	0.44	0.51	0.57	0.63	0.68	0.72	0.77	0.78	0.74	
	1.50	0.03	0.05	0.08	0.11	0.13	0.15	0.20	0.28	0.33	0.45	0.52	0.58	0.64	0.68	0.72	0.78	0.79	0.75	
	3.00	0.03	0.05	0.08	0.11	0.13	0.15	0.21	0.28	0.33	0.45	0.52	0.58	0.64	0.69	0.73	0.78	0.80	0.76	
63	1.00	0.03	0.05	0.09	0.12	0.14	0.17	0.23	0.31	0.37	0.49	0.56	0.63	0.68	0.73	0.76	0.79	0.77	0.67	
	1.05	0.03	0.05	0.09	0.12	0.14	0.17	0.23	0.31	0.37	0.49	0.57	0.63	0.69	0.73	0.77	0.80	0.77	0.68	
	1.20	0.03	0.05	0.09	0.12	0.15	0.17	0.23	0.31	0.37	0.50	0.57	0.64	0.70	0.74	0.78	0.81	0.79	0.70	
	1.50	0.03	0.06	0.09	0.12	0.15	0.17	0.23	0.31	0.37	0.50	0.58	0.65	0.70	0.75	0.79	0.82	0.80	0.71	
	3.00	0.03	0.06	0.09	0.12	0.15	0.17	0.23	0.32	0.38	0.51	0.58	0.65	0.71	0.76	0.79	0.83	0.81	0.72	
71	1.00	0.03	0.06	0.10	0.13	0.16	0.19	0.26	0.35	0.41	0.55	0.63	0.70	0.75	0.79	0.82	0.81	0.73		
	1.05	0.03	0.06	0.10	0.13	0.16	0.19	0.26	0.35	0.42	0.55	0.63	0.70	0.76	0.80	0.82	0.82	0.74		
	1.20	0.03	0.06	0.10	0.13	0.17	0.20	0.26	0.35	0.42	0.56	0.64	0.71	0.77	0.81	0.83	0.83	0.75		
	1.50	0.03	0.06	0.10	0.13	0.17	0.20	0.26	0.36	0.42	0.56	0.65	0.71	0.77	0.81	0.84	0.84	0.76		
	3.00	0.03	0.06	0.10	0.14	0.17	0.20	0.26	0.36	0.42	0.57	0.65	0.72	0.78	0.82	0.85	0.85	0.77		
80	1.00	0.04	0.07	0.11	0.15	0.18	0.22	0.29	0.39	0.47	0.62	0.70	0.77	0.82	0.85	0.85	0.80	0.62		
	1.05	0.04	0.07	0.11	0.15	0.19	0.22	0.29	0.39	0.47	0.62	0.70	0.77	0.82	0.85	0.86	0.80	0.63		
	1.20	0.04	0.07	0.12	0.15	0.19	0.22	0.29	0.40	0.47	0.62	0.71	0.78	0.83	0.86	0.87	0.81	0.64		
	1.50	0.04	0.07	0.12	0.15	0.19	0.22	0.29	0.40	0.48	0.63	0.71	0.78	0.84	0.87	0.88	0.82	0.66		
	3.00	0.04	0.07	0.12	0.15	0.19	0.22	0.30	0.40	0.48	0.63	0.72	0.79	0.84	0.87	0.88	0.83	0.66		
V_{max}	m/s																			60

Power capacity rating P_R for CONTI-V MULTIRIB® Belt – section PJ

Power capacity rating P_R (kW) for one rib as a function of the effective diameter of the small pulley d_{bk} , the transmission ratio i , the rpm of the small pulley n_k and the effective length $L_b = 1016$ mm.

Power capacity rating P_R for CONTI-V MULTIRIB® Belt – Section PJ

Table 26

d_{bk} mm	i or 1:i	Rpm of the small pulley n_k (min ⁻¹)														
		200	400	700	950	1200	1450	2000	2850	3500	5000	6000	7000	8000	9000	10000
20	1.00	0.01	0.02	0.04	0.05	0.05	0.06	0.08	0.10	0.12	0.16	0.18	0.20	0.21	0.23	0.24
	1.05	0.01	0.02	0.04	0.05	0.06	0.07	0.08	0.11	0.13	0.16	0.19	0.21	0.23	0.24	0.26
	1.20	0.01	0.02	0.04	0.05	0.06	0.07	0.09	0.12	0.14	0.18	0.20	0.23	0.25	0.27	0.29
	1.50	0.01	0.03	0.04	0.05	0.06	0.07	0.09	0.12	0.14	0.19	0.22	0.24	0.27	0.29	0.31
	3.00	0.01	0.03	0.04	0.05	0.06	0.07	0.10	0.13	0.15	0.20	0.23	0.25	0.28	0.30	0.32
25	1.00	0.02	0.03	0.05	0.07	0.08	0.10	0.12	0.16	0.19	0.26	0.29	0.33	0.36	0.39	0.42
	1.05	0.02	0.03	0.05	0.07	0.08	0.10	0.13	0.17	0.20	0.26	0.30	0.34	0.37	0.41	0.43
	1.20	0.02	0.03	0.06	0.07	0.09	0.10	0.13	0.18	0.21	0.28	0.32	0.36	0.40	0.43	0.46
	1.50	0.02	0.04	0.06	0.07	0.09	0.10	0.14	0.18	0.22	0.29	0.33	0.37	0.41	0.45	0.49
	3.00	0.02	0.04	0.06	0.08	0.09	0.11	0.14	0.19	0.22	0.30	0.34	0.39	0.43	0.47	0.50
31.5	1.00	0.03	0.05	0.07	0.10	0.12	0.14	0.18	0.24	0.29	0.38	0.44	0.49	0.55	0.59	0.64
	1.05	0.03	0.05	0.07	0.10	0.12	0.14	0.18	0.24	0.29	0.39	0.45	0.50	0.56	0.61	0.65
	1.20	0.03	0.05	0.08	0.10	0.12	0.14	0.19	0.25	0.30	0.40	0.47	0.53	0.58	0.63	0.68
	1.50	0.03	0.05	0.08	0.10	0.12	0.15	0.19	0.26	0.31	0.41	0.48	0.54	0.60	0.65	0.70
	3.00	0.03	0.05	0.08	0.10	0.13	0.15	0.20	0.26	0.31	0.42	0.49	0.55	0.61	0.67	0.72
35.5	1.00	0.03	0.05	0.09	0.11	0.14	0.16	0.21	0.29	0.34	0.46	0.53	0.59	0.66	0.71	0.77
	1.05	0.03	0.05	0.09	0.11	0.14	0.16	0.22	0.29	0.35	0.46	0.54	0.60	0.67	0.73	0.78
	1.20	0.03	0.06	0.09	0.12	0.14	0.17	0.22	0.30	0.36	0.48	0.55	0.62	0.69	0.75	0.81
	1.50	0.03	0.06	0.09	0.12	0.15	0.17	0.23	0.31	0.36	0.49	0.57	0.64	0.71	0.77	0.83
	3.00	0.03	0.06	0.09	0.12	0.15	0.17	0.23	0.31	0.37	0.50	0.58	0.65	0.72	0.79	0.85
40	1.00	0.03	0.06	0.10	0.13	0.16	0.19	0.25	0.34	0.40	0.54	0.62	0.70	0.78	0.84	0.90
	1.05	0.03	0.06	0.10	0.13	0.16	0.19	0.25	0.34	0.41	0.55	0.63	0.71	0.79	0.85	0.92
	1.20	0.03	0.06	0.10	0.14	0.17	0.20	0.26	0.35	0.42	0.56	0.65	0.73	0.81	0.88	0.95
	1.50	0.04	0.06	0.11	0.14	0.17	0.20	0.26	0.36	0.42	0.57	0.66	0.75	0.83	0.90	0.97
	3.00	0.04	0.07	0.11	0.14	0.17	0.20	0.27	0.36	0.43	0.58	0.67	0.76	0.84	0.92	0.98
45	1.00	0.04	0.07	0.12	0.15	0.19	0.22	0.29	0.39	0.47	0.63	0.73	0.82	0.90	0.98	1.04
	1.05	0.04	0.07	0.12	0.15	0.19	0.22	0.29	0.40	0.47	0.64	0.74	0.83	0.91	0.99	1.06
	1.20	0.04	0.07	0.12	0.16	0.19	0.23	0.30	0.41	0.48	0.65	0.75	0.85	0.94	1.02	1.09
	1.50	0.04	0.07	0.12	0.16	0.20	0.23	0.30	0.41	0.49	0.66	0.77	0.87	0.96	1.04	1.11
	3.00	0.04	0.08	0.12	0.16	0.20	0.23	0.31	0.42	0.50	0.67	0.78	0.88	0.97	1.05	1.13
50	1.00	0.04	0.08	0.13	0.17	0.21	0.25	0.33	0.45	0.54	0.72	0.83	0.93	1.02	1.11	1.18
	1.05	0.04	0.08	0.13	0.17	0.21	0.25	0.33	0.45	0.54	0.73	0.84	0.94	1.04	1.12	1.19
	1.20	0.04	0.08	0.14	0.18	0.22	0.26	0.34	0.46	0.55	0.74	0.86	0.96	1.06	1.14	1.22
	1.50	0.05	0.08	0.14	0.18	0.22	0.26	0.34	0.47	0.56	0.75	0.87	0.98	1.08	1.17	1.24
	3.00	0.05	0.08	0.14	0.18	0.22	0.26	0.35	0.47	0.56	0.76	0.88	0.99	1.09	1.18	1.26
56	1.00	0.05	0.09	0.15	0.20	0.24	0.29	0.38	0.52	0.61	0.82	0.95	1.06	1.16	1.25	1.32
	1.05	0.05	0.09	0.15	0.20	0.24	0.29	0.38	0.52	0.62	0.83	0.96	1.07	1.17	1.26	1.34
	1.20	0.05	0.09	0.15	0.20	0.25	0.29	0.39	0.53	0.63	0.84	0.97	1.09	1.20	1.29	1.36
	1.50	0.05	0.10	0.16	0.20	0.25	0.30	0.39	0.53	0.64	0.85	0.99	1.11	1.21	1.31	1.39
	3.00	0.05	0.10	0.16	0.21	0.25	0.30	0.40	0.54	0.64	0.86	1.00	1.12	1.23	1.32	1.40
60	1.00	0.05	0.10	0.16	0.21	0.26	0.31	0.41	0.56	0.66	0.89	1.02	1.14	1.25	1.34	1.41
	1.05	0.05	0.10	0.16	0.22	0.27	0.31	0.41	0.56	0.67	0.90	1.03	1.15	1.26	1.35	1.42
	1.20	0.05	0.10	0.17	0.22	0.27	0.32	0.42	0.57	0.68	0.91	1.05	1.17	1.28	1.38	1.45
	1.50	0.06	0.10	0.17	0.22	0.27	0.32	0.42	0.58	0.69	0.92	1.06	1.19	1.30	1.40	1.47
	3.00	0.06	0.10	0.17	0.22	0.27	0.32	0.43	0.58	0.69	0.93	1.07	1.20	1.31	1.41	1.49
63	1.00	0.06	0.11	0.17	0.23	0.28	0.33	0.44	0.59	0.70	0.94	1.08	1.20	1.31	1.40	1.47
	1.05	0.06	0.11	0.17	0.23	0.28	0.33	0.44	0.59	0.71	0.95	1.09	1.21	1.32	1.41	1.48
	1.20	0.06	0.11	0.18	0.23	0.28	0.33	0.44	0.60	0.72	0.96	1.11	1.23	1.34	1.44	1.51
	1.50	0.06	0.11	0.18	0.23	0.29	0.34	0.45	0.61	0.73	0.97	1.12	1.25	1.36	1.46	1.53
	3.00	0.06	0.11	0.18	0.23	0.29	0.34	0.45	0.61	0.73	0.98	1.13	1.26	1.38	1.47	1.55
67	1.00	0.06	0.11	0.19	0.24	0.30	0.35	0.47	0.63	0.75	1.00	1.15	1.28	1.39	1.48	1.54
	1.05	0.06	0.11	0.19	0.24	0.30	0.35	0.47	0.64	0.76	1.01	1.16	1.29	1.40	1.49	1.55
	1.20	0.06	0.11	0.19	0.25	0.30	0.36	0.48	0.65	0.77	1.03	1.18	1.31	1.42	1.52	1.58
	1.50	0.06	0.12	0.19	0.25	0.31	0.36	0.48	0.65	0.78	1.04	1.19	1.33	1.44	1.54	1.61
	3.00	0.06	0.12	0.19	0.25	0.31	0.36	0.48	0.66	0.78	1.05	1.20	1.34	1.46	1.55	1.62
71	1.00	0.06	0.12	0.20	0.26	0.32	0.38	0.50	0.68	0.80	1.07	1.22	1.35	1.46	1.55	1.60
	1.05	0.07	0.12	0.20	0.26	0.32	0.38	0.50	0.68	0.81	1.08	1.23	1.36	1.48	1.56	1.62
	1.20	0.07	0.12	0.20	0.26	0.32	0.38	0.51	0.69	0.82	1.09	1.25	1.38	1.50	1.59	1.65
	1.50	0.07	0.12	0.20	0.27	0.33	0.39	0.51	0.69	0.83	1.10	1.26	1.40	1.52	1.61	1.67
	3.00	0.07	0.12	0.20	0.27	0.33	0.39	0.51	0.70	0.83	1.11	1.27	1.41	1.53	1.62	1.68
75	1.00	0.07	0.13	0.21	0.27	0.34	0.40	0.53	0.72	0.85	1.13	1.29	1.42	1.53	1.61	1.66
	1.05	0.07	0.13	0.21	0.28	0.34	0.40	0.53	0.72	0.86	1.14	1.30	1.44	1.54	1.62	1.67
	1.20	0.07	0.13	0.21	0.28	0.34	0.41	0.54	0.73	0.87	1.15	1.32	1.46	1.57	1.65	1.70
	1.50	0.07	0.13	0.21	0.28	0.35	0.41	0.54	0.74	0.87	1.16	1.33	1.47	1.59	1.67	1.72
	3.00	0.07	0.13	0.22	0.28	0.35	0.41	0.54	0.74	0.88	1.17	1.34	1.48	1.60	1.69	1.74
v_{max}	m/s															

Power capacity rating P_R for CONTI-V MULTIRIB® Belt – Section PJ

Table 26

d_{bk} mm	i or 1:i	Rpm of the small pulley n_k (min ⁻¹)														
		200	400	700	950	1200	1450	2000	2850	3500	5000	6000	7000	8000	9000	10000
80	1.00	0.07	0.14	0.22	0.29	0.36	0.43	0.57	0.77	0.91	1.21	1.37	1.51	1.61	1.66	1.71
	1.05	0.07	0.14	0.23	0.30	0.36	0.43	0.57	0.77	0.92	1.21	1.38	1.52	1.62	1.70	1.73
	1.20	0.07	0.14	0.23	0.30	0.37	0.43	0.58	0.78	0.93	1.23	1.40	1.54	1.65	1.72	1.76
	1.50	0.07	0.14	0.23	0.30	0.37	0.44	0.58	0.79	0.93	1.24	1.41	1.55	1.67	1.74	1.78
	3.00	0.08	0.14	0.23	0.30	0.37	0.44	0.58	0.79	0.94	1.25	1.42	1.57	1.68	1.76	1.79
85	1.00	0.08	0.15	0.24	0.31	0.39	0.46	0.60	0.82	0.97	1.28	1.45	1.59	1.68	1.74	1.75
	1.05	0.08	0.15	0.24	0.32	0.39	0.46	0.61	0.82	0.98	1.29	1.46	1.60	1.70	1.75	1.77
	1.20	0.08	0.15	0.24	0.32	0.39	0.46	0.61	0.83	0.99	1.30	1.48	1.62	1.72	1.78	1.79
	1.50	0.08	0.15	0.24	0.32	0.39	0.47	0.62	0.84	0.99	1.31	1.49	1.63	1.74	1.80	1.82
	3.00	0.08	0.15	0.25	0.32	0.40	0.47	0.62	0.84	1.00	1.32	1.50	1.64	1.75	1.81	1.83
90	1.00	0.08	0.15	0.25	0.33	0.41	0.49	0.64	0.87	1.03	1.35	1.52	1.66	1.75	1.79	1.77
	1.05	0.08	0.16	0.26	0.34	0.41	0.49	0.65	0.87	1.03	1.36	1.53	1.67	1.76	1.80	1.79
	1.20	0.08	0.16	0.26	0.34	0.42	0.49	0.65	0.88	1.04	1.37	1.55	1.69	1.78	1.83	1.82
	1.50	0.08	0.16	0.26	0.34	0.42	0.49	0.66	0.89	1.05	1.38	1.56	1.70	1.80	1.85	1.84
	3.00	0.08	0.16	0.26	0.34	0.42	0.50	0.66	0.89	1.06	1.39	1.57	1.71	1.81	1.86	1.86
95	1.00	0.09	0.16	0.27	0.35	0.43	0.51	0.68	0.92	1.09	1.42	1.59	1.72	1.80	1.82	1.78
	1.05	0.09	0.16	0.27	0.35	0.44	0.52	0.68	0.92	1.09	1.43	1.60	1.73	1.81	1.83	1.79
	1.20	0.09	0.17	0.27	0.36	0.44	0.52	0.69	0.93	1.10	1.44	1.62	1.75	1.63	1.86	1.82
	1.50	0.09	0.17	0.27	0.36	0.44	0.52	0.69	0.94	1.11	1.45	1.63	1.77	1.65	1.88	1.84
	3.00	0.09	0.17	0.27	0.36	0.44	0.53	0.70	0.94	1.12	1.46	1.64	1.78	1.87	1.89	1.86
100	1.00	0.09	0.17	0.28	0.37	0.46	0.54	0.72	0.97	1.14	1.49	1.66	1.78	1.84	1.84	1.76
	1.05	0.09	0.17	0.28	0.37	0.46	0.54	0.72	0.97	1.15	1.49	1.67	1.79	1.86	1.85	1.78
	1.20	0.09	0.17	0.29	0.38	0.46	0.55	0.73	0.98	1.16	1.51	1.68	1.81	1.88	1.88	1.81
	1.50	0.09	0.17	0.29	0.38	0.47	0.55	0.73	0.99	1.17	1.52	1.70	1.83	1.90	1.90	1.83
	3.00	0.09	0.18	0.29	0.38	0.47	0.55	0.73	0.99	1.17	1.53	1.71	1.84	1.91	1.91	1.85
112	1.00	0.10	0.19	0.32	0.42	0.51	0.61	0.80	1.08	1.27	1.63	1.80	1.89	1.91	1.83	1.65
	1.05	0.10	0.19	0.32	0.42	0.52	0.61	0.81	1.09	1.28	1.64	1.81	1.90	1.92	1.84	1.67
	1.20	0.10	0.20	0.32	0.42	0.52	0.61	0.81	1.09	1.29	1.65	1.82	1.92	1.94	1.87	1.70
	1.50	0.11	0.20	0.32	0.42	0.52	0.62	0.82	1.10	1.30	1.67	1.84	1.94	1.96	1.89	1.72
	3.00	0.11	0.20	0.32	0.43	0.52	0.62	0.82	1.11	1.30	1.67	1.85	1.95	1.97	1.90	1.73
125	1.00	0.12	0.22	0.36	0.47	0.58	0.68	0.90	1.20	1.41	1.77	1.92	1.96	1.90	1.72	
	1.05	0.12	0.22	0.36	0.47	0.58	0.68	0.90	1.21	1.41	1.78	1.93	1.98	1.91	1.73	
	1.20	0.12	0.22	0.36	0.47	0.58	0.69	0.91	1.21	1.42	1.80	1.94	2.00	1.94	1.75	
	1.50	0.12	0.22	0.36	0.47	0.58	0.69	0.91	1.22	1.43	1.81	1.96	2.01	1.96	1.77	
	3.00	0.12	0.22	0.36	0.48	0.59	0.69	0.91	1.23	1.44	1.81	1.97	2.02	1.97	1.79	
140	1.00	0.13	0.24	0.40	0.52	0.64	0.76	1.00	1.33	1.55	1.91	2.01	1.98	1.80		
	1.05	0.13	0.24	0.40	0.53	0.65	0.76	1.00	1.34	1.56	1.92	2.02	1.99	1.81		
	1.20	0.13	0.24	0.40	0.53	0.65	0.77	1.01	1.35	1.57	1.93	2.04	2.01	1.83		
	1.50	0.13	0.24	0.40	0.53	0.65	0.77	1.01	1.35	1.58	1.94	2.05	2.02	1.85		
	3.00	0.13	0.25	0.41	0.53	0.65	0.77	1.02	1.36	1.58	1.95	2.06	2.04	1.86		
160	1.00	0.15	0.28	0.46	0.60	0.73	0.87	1.14	1.50	1.73	2.04	2.05	1.87			
	1.05	0.15	0.28	0.46	0.60	0.74	0.87	1.14	1.50	1.73	2.05	2.06	1.88			
	1.20	0.15	0.28	0.46	0.60	0.74	0.87	1.14	1.51	1.74	2.06	2.08	1.90			
	1.50	0.15	0.28	0.46	0.60	0.74	0.88	1.15	1.52	1.75	2.07	2.09	1.91			
	3.00	0.15	0.28	0.46	0.61	0.74	0.88	1.15	1.52	1.76	2.08	2.10	1.92			
180	1.00	0.17	0.31	0.51	0.67	0.82	0.97	1.27	1.65	1.88	2.11	1.99				
	1.05	0.17	0.31	0.51	0.67	0.82	0.97	1.27	1.66	1.88	2.12	1.99				
	1.20	0.17	0.31	0.51	0.67	0.83	0.97	1.27	1.66	1.89	2.13	2.01				
	1.50	0.17	0.31	0.52	0.68	0.83	0.98	1.28	1.67	1.90	2.14	2.02				
	3.00	0.17	0.31	0.52	0.68	0.83	0.98	1.28	1.68	1.91	2.15	2.03				
200	1.00	0.18	0.34	0.57	0.74	0.91	1.07	1.39	1.79	2.01	2.11					
	1.05	0.18	0.34	0.57	0.74	0.91	1.07	1.39	1.79	2.01	2.12					
	1.20	0.18	0.34	0.57	0.75	0.91	1.07	1.40	1.80	2.02	2.13					
	1.50	0.19	0.35	0.57	0.75	0.92	1.08	1.40	1.81	2.03	2.14					
	3.00	0.19	0.35	0.57	0.75	0.92	1.08	1.41	1.81	2.03	2.15					
250	1.00	0.23	0.42	0.70	0.92	1.12	1.31	1.67	2.07	2.20						
	1.05	0.23	0.43	0.70	0.92	1.12	1.31	1.67	2.07	2.20						
	1.20	0.23	0.43	0.70	0.92	1.12	1.31	1.68	2.08	2.21						
	1.50	0.23	0.43	0.70	0.92	1.13	1.32	1.68	2.09	2.22						
	3.00	0.23	0.43	0.71	0.92	1.13	1.32	1.69	2.09	2.23						
V_{max}	m/s	60														

Power capacity rating P_R for CONTI-V MULTIRIB® Belt – section PK

Power capacity rating P_R (kW) for one rib as a function of the effective diameter of the small pulley d_{bk} , the transmission ratio i , the rpm of the small pulley n_k and the effective length $L_b = 1610$ mm.

Power capacity rating P_R for CONTI-V MULTIRIB® Belt – Section PK

Table 27

d_{bk} mm	i or 1:i	Rpm of the small pulley n_k (min ⁻¹)															
		200	400	700	950	1450	2000	2400	2850	3500	5000	5500	6000	6500	7000	7500	8000
45	1.00	0.07	0.12	0.18	0.23	0.31	0.40	0.45	0.50	0.57	0.70	0.73	0.76	0.78	0.80	0.81	0.81
	1.05	0.07	0.12	0.19	0.24	0.33	0.41	0.47	0.53	0.61	0.75	0.78	0.82	0.84	0.86	0.88	0.89
	1.20	0.07	0.13	0.20	0.26	0.35	0.45	0.51	0.58	0.67	0.84	0.88	0.92	0.96	0.99	1.01	1.03
	1.50	0.08	0.13	0.21	0.27	0.37	0.48	0.55	0.62	0.72	0.91	0.96	1.01	1.05	1.09	1.12	1.14
	3.00	0.08	0.14	0.22	0.28	0.39	0.50	0.57	0.65	0.75	0.96	1.01	1.07	1.11	1.15	1.19	1.22
50	1.00	0.08	0.15	0.23	0.29	0.40	0.51	0.59	0.66	0.76	0.96	1.01	1.05	1.09	1.12	1.14	1.16
	1.05	0.08	0.15	0.23	0.30	0.41	0.53	0.61	0.69	0.80	1.00	1.06	1.11	1.15	1.18	1.21	1.23
	1.20	0.09	0.16	0.25	0.31	0.44	0.57	0.65	0.74	0.86	1.09	1.15	1.21	1.26	1.31	1.34	1.37
	1.50	0.09	0.16	0.26	0.33	0.46	0.59	0.68	0.78	0.91	1.16	1.23	1.30	1.35	1.41	1.45	1.48
	3.00	0.09	0.17	0.26	0.34	0.48	0.61	0.71	0.81	0.94	1.21	1.29	1.36	1.42	1.47	1.52	1.56
56	1.00	0.10	0.18	0.28	0.36	0.50	0.65	0.75	0.85	0.99	1.25	1.32	1.39	1.44	1.49	1.52	1.55
	1.05	0.10	0.18	0.29	0.37	0.52	0.67	0.77	0.88	1.02	1.30	1.37	1.44	1.50	1.55	1.59	1.62
	1.20	0.11	0.19	0.30	0.39	0.54	0.70	0.81	0.93	1.08	1.39	1.47	1.55	1.62	1.67	1.72	1.76
	1.50	0.11	0.19	0.31	0.40	0.56	0.73	0.85	0.97	1.13	1.46	1.55	1.63	1.71	1.77	1.83	1.87
	3.00	0.11	0.20	0.32	0.41	0.58	0.75	0.87	1.00	1.17	1.51	1.60	1.69	1.77	1.84	1.90	1.95
63	1.00	0.12	0.21	0.34	0.44	0.62	0.81	0.93	1.07	1.24	1.59	1.68	1.76	1.83	1.89	1.93	1.97
	1.05	0.12	0.22	0.35	0.45	0.64	0.83	0.96	1.09	1.27	1.63	1.73	1.82	1.89	1.95	2.00	2.04
	1.20	0.12	0.23	0.36	0.47	0.66	0.86	1.00	1.14	1.34	1.72	1.83	1.92	2.01	2.08	2.14	2.18
	1.50	0.13	0.23	0.37	0.48	0.68	0.89	1.03	1.18	1.39	1.79	1.90	2.01	2.10	2.18	2.24	2.29
	3.00	0.13	0.24	0.38	0.49	0.70	0.91	1.06	1.21	1.42	1.84	1.96	2.07	2.16	2.25	2.32	2.37
71	1.00	0.14	0.26	0.41	0.53	0.76	0.99	1.14	1.31	1.53	1.95	2.07	2.17	2.25	2.32	2.36	2.40
	1.05	0.14	0.26	0.42	0.54	0.77	1.01	1.16	1.33	1.56	2.00	2.12	2.22	2.31	2.38	2.43	2.47
	1.20	0.15	0.27	0.43	0.56	0.80	1.04	1.21	1.38	1.62	2.09	2.21	2.33	2.42	2.50	2.57	2.61
	1.50	0.15	0.27	0.44	0.57	0.82	1.07	1.24	1.42	1.67	2.16	2.29	2.41	2.51	2.60	2.67	2.72
	3.00	0.15	0.28	0.45	0.58	0.83	1.09	1.26	1.45	1.71	2.21	2.35	2.47	2.58	2.67	2.75	2.80
80	1.00	0.17	0.30	0.49	0.64	0.91	1.19	1.37	1.57	1.84	2.35	2.48	2.59	2.68	2.75	2.79	2.81
	1.05	0.17	0.31	0.50	0.64	0.92	1.20	1.40	1.60	1.87	2.39	2.53	2.64	2.74	2.81	2.86	2.88
	1.20	0.17	0.31	0.51	0.66	0.95	1.24	1.44	1.65	1.93	2.48	2.63	2.75	2.85	2.93	2.99	3.02
	1.50	0.18	0.32	0.52	0.68	0.97	1.27	1.47	1.69	1.98	2.55	2.70	2.83	2.95	3.03	3.10	3.14
	3.00	0.18	0.32	0.53	0.68	0.98	1.29	1.50	1.72	2.02	2.60	2.76	2.89	3.01	3.10	3.17	3.22
90	1.00	0.19	0.36	0.58	0.75	1.07	1.40	1.63	1.86	2.18	2.76	2.90	3.02	3.11	3.16	3.19	3.17
	1.05	0.20	0.36	0.58	0.76	1.09	1.42	1.65	1.89	2.21	2.80	2.95	3.07	3.16	3.23	3.25	3.25
	1.20	0.20	0.37	0.59	0.77	1.11	1.46	1.69	1.94	2.27	2.89	3.05	3.18	3.28	3.35	3.39	3.39
	1.50	0.20	0.37	0.60	0.79	1.13	1.48	1.72	1.98	2.32	2.96	3.13	3.26	3.37	3.45	3.49	3.50
	3.00	0.20	0.38	0.61	0.80	1.15	1.50	1.75	2.01	2.35	3.01	3.18	3.32	3.44	3.52	3.57	3.58
100	1.00	0.22	0.41	0.66	0.86	1.23	1.61	1.87	2.14	2.50	3.14	3.28	3.40	3.47	3.50	3.49	3.43
	1.05	0.22	0.41	0.67	0.87	1.25	1.63	1.89	2.17	2.53	3.18	3.33	3.45	3.53	3.57	3.56	3.50
	1.20	0.23	0.42	0.68	0.89	1.27	1.67	1.94	2.22	2.59	3.27	3.43	3.56	3.64	3.69	3.69	3.65
	1.50	0.23	0.42	0.69	0.90	1.29	1.70	1.97	2.26	2.64	3.34	3.51	3.64	3.74	3.79	3.80	3.76
	3.00	0.23	0.43	0.70	0.91	1.31	1.72	1.99	2.29	2.68	3.39	3.56	3.70	3.80	3.86	3.87	3.84
112	1.00	0.25	0.47	0.76	0.99	1.43	1.86	2.16	2.47	2.87	3.55	3.69	3.78	3.82	3.80	3.72	3.58
	1.05	0.26	0.47	0.77	1.00	1.44	1.88	2.18	2.50	2.90	3.60	3.74	3.84	3.88	3.87	3.79	3.65
	1.20	0.26	0.48	0.78	1.02	1.46	1.92	2.23	2.55	2.96	3.69	3.84	3.94	4.00	3.99	3.93	3.80
	1.50	0.26	0.48	0.79	1.03	1.48	1.95	2.26	2.59	3.01	3.76	3.92	4.03	4.09	4.09	4.03	3.91
	3.00	0.26	0.49	0.80	1.04	1.50	1.97	2.28	2.62	3.05	3.81	3.97	4.09	4.15	4.16	4.11	3.99
125	1.00	0.29	0.53	0.87	1.13	1.63	2.13	2.47	2.81	3.25	3.94	4.06	4.11	4.08	3.98	3.80	3.53
	1.05	0.29	0.54	0.88	1.14	1.64	2.15	2.49	2.84	3.28	3.99	4.11	4.16	4.14	4.05	3.87	3.60
	1.20	0.29	0.54	0.89	1.16	1.67	2.18	2.53	2.89	3.35	4.08	4.21	4.27	4.26	4.17	4.00	3.75
	1.50	0.30	0.55	0.90	1.17	1.69	2.21	2.56	2.93	3.40	4.15	4.28	4.35	4.35	4.27	4.11	3.86
	3.00	0.30	0.55	0.90	1.18	1.70	2.23	2.59	2.96	3.43	4.20	4.34	4.41	4.41	4.34	4.18	3.94
140	1.00	0.33	0.61	0.99	1.29	1.86	2.43	2.80	3.19	3.66	4.32	4.38	4.35	4.22	3.98		
	1.05	0.33	0.61	1.00	1.30	1.87	2.45	2.83	3.21	3.69	4.36	4.43	4.40	4.28	4.05		
	1.20	0.33	0.62	1.01	1.32	1.90	2.48	2.87	3.26	3.76	4.45	4.53	4.51	4.39	4.17		
	1.50	0.34	0.62	1.02	1.33	1.92	2.51	2.90	3.30	3.80	4.52	4.60	4.59	4.48	4.27		
	3.00	0.34	0.63	1.03	1.34	1.93	2.53	2.93	3.33	3.84	4.57	4.66	4.65	4.55	4.34		
160	1.00	0.38	0.70	1.15	1.51	2.16	2.81	3.24	3.66	4.15	4.67	4.62	4.43				
	1.05	0.38	0.71	1.16	1.51	2.17	2.83	3.26	3.68	4.19	4.72	4.67	4.48				
	1.20	0.39	0.71	1.17	1.53	2.20	2.87	3.30	3.74	4.25	4.81	4.76	4.59				
	1.50	0.39	0.72	1.18	1.54	2.22	2.89	3.33	3.78	4.30	4.88	4.84	4.67				
	3.00	0.39	0.72	1.19	1.55	2.24	2.91	3.36	3.80	4.33	4.93	4.90	4.73				
v_{max}	m/s	50															

Power capacity rating P_R for CONTI-V MULTIRIB® Belt – Section PK

Table 27

d_{bk} mm	i or 1:i	Rpm of the small pulley n_k (min ⁻¹)															
		200	400	700	950	1450	2000	2400	2850	3500	5000	5500	6000	6500	7000	7500	8000
180	1.00	0.43	0.80	1.31	1.71	2.46	3.18	3.64	4.09	4.58	4.84	4.61					
	1.05	0.43	0.80	1.32	1.72	2.47	3.20	3.67	4.12	4.61	4.89	4.66					
	1.20	0.44	0.81	1.33	1.74	2.49	3.23	3.71	4.17	4.67	4.98	4.76					
	1.50	0.44	0.82	1.34	1.75	2.51	3.26	3.74	4.21	4.72	5.05	4.83					
	3.00	0.44	0.82	1.35	1.76	2.53	3.28	3.77	4.24	4.76	5.10	4.89					
200	1.00	0.48	0.90	1.47	1.92	2.74	3.53	4.02	4.48	4.93	4.81						
	1.05	0.48	0.90	1.48	1.93	2.75	3.55	4.05	4.51	4.96	4.85						
	1.20	0.49	0.91	1.49	1.94	2.78	3.59	4.09	4.56	5.03	4.94						
	1.50	0.49	0.91	1.50	1.96	2.80	3.62	4.12	4.60	5.07	5.01						
	3.00	0.49	0.92	1.51	1.97	2.82	3.64	4.15	4.63	5.11	5.06						
224	1.00	0.54	1.01	1.66	2.16	3.07	3.93	4.44	4.89	5.25							
	1.05	0.55	1.01	1.66	2.17	3.09	3.95	4.47	4.91	5.28							
	1.20	0.55	1.02	1.67	2.18	3.11	3.99	4.51	4.97	5.34							
	1.50	0.55	1.03	1.68	2.20	3.13	4.01	4.54	5.01	5.39							
	3.00	0.55	1.03	1.69	2.21	3.15	4.03	4.57	5.03	5.42							
250	1.00	0.61	1.13	1.85	2.41	3.42	4.33	4.85	5.25								
	1.05	0.61	1.13	1.86	2.42	3.43	4.35	4.87	5.28								
	1.20	0.61	1.14	1.87	2.44	3.46	4.39	4.91	5.33								
	1.50	0.62	1.15	1.88	2.45	3.48	4.42	4.95	5.37								
	3.00	0.62	1.15	1.89	2.46	3.49	4.44	4.97	5.40								
v_{max}	m/s	50															

Power capacity rating P_R for CONTI-V MULTIRIB® Belt – section PL

Power capacity rating P_R (kW) for one rib as a function of the effective diameter of the small pulley d_{bk} , the transmission ratio i , the rpm of the small pulley n_k and the effective length $L_b = 2096$ mm.

Power capacity rating P_R for CONTI-V MULTIRIB® Belt – Section PL

Table 28

d_{bk} mm	i or 1:i	Rpm of the small pulley n_k (min ⁻¹)																	
		200	400	700	950	1200	1450	2000	2400	2850	3200	3500	3800	4000	4300	4600	5000	5500	6000
75	1.00	0.15	0.26	0.40	0.50	0.60	0.68	0.85	0.95	1.04	1.11	1.15	1.18	1.20	1.22	1.23	1.23	1.20	1.13
	1.05	0.16	0.27	0.42	0.52	0.62	0.71	0.89	1.00	1.10	1.17	1.22	1.26	1.29	1.31	1.33	1.33	1.31	1.26
	1.20	0.16	0.29	0.45	0.56	0.67	0.77	0.97	1.10	1.22	1.30	1.37	1.42	1.45	1.49	1.52	1.54	1.54	1.51
	1.50	0.17	0.30	0.47	0.59	0.71	0.82	1.04	1.18	1.31	1.41	1.48	1.54	1.58	1.63	1.66	1.70	1.72	1.70
	3.00	0.18	0.31	0.48	0.62	0.74	0.85	1.08	1.23	1.38	1.48	1.56	1.63	1.67	1.73	1.77	1.81	1.84	1.84
80	1.00	0.17	0.30	0.46	0.58	0.70	0.80	1.00	1.13	1.25	1.33	1.39	1.43	1.46	1.49	1.51	1.51	1.49	1.43
	1.05	0.18	0.31	0.48	0.60	0.72	0.83	1.04	1.18	1.31	1.39	1.46	1.51	1.54	1.58	1.60	1.62	1.60	1.55
	1.20	0.18	0.32	0.51	0.64	0.77	0.89	1.12	1.28	1.42	1.53	1.60	1.67	1.71	1.75	1.79	1.82	1.83	1.80
	1.50	0.19	0.34	0.53	0.67	0.81	0.94	1.19	1.35	1.52	1.63	1.72	1.79	1.84	1.89	1.94	1.98	2.01	2.00
	3.00	0.20	0.35	0.55	0.70	0.84	0.97	1.24	1.41	1.58	1.70	1.80	1.88	1.93	1.99	2.05	2.10	2.13	2.13
90	1.00	0.21	0.37	0.58	0.74	0.89	1.03	1.30	1.48	1.65	1.76	1.84	1.91	1.95	2.00	2.03	2.05	2.03	1.96
	1.05	0.21	0.38	0.60	0.76	0.92	1.06	1.34	1.53	1.71	1.83	1.92	1.99	2.04	2.09	2.13	2.15	2.14	2.08
	1.20	0.22	0.40	0.63	0.80	0.97	1.12	1.43	1.63	1.82	1.96	2.06	2.15	2.20	2.26	2.31	2.36	2.37	2.33
	1.50	0.23	0.41	0.65	0.83	1.00	1.17	1.49	1.70	1.92	2.06	2.17	2.27	2.33	2.40	2.46	2.52	2.55	2.53
	3.00	0.23	0.42	0.67	0.85	1.03	1.20	1.54	1.76	1.98	2.14	2.25	2.36	2.42	2.50	2.57	2.63	2.67	2.66
100	1.00	0.25	0.44	0.70	0.90	1.08	1.26	1.60	1.82	2.03	2.18	2.28	2.37	2.42	2.48	2.51	2.53	2.50	2.41
	1.05	0.25	0.45	0.72	0.92	1.11	1.29	1.64	1.87	2.09	2.24	2.35	2.45	2.50	2.57	2.61	2.64	2.62	2.53
	1.20	0.26	0.47	0.75	0.96	1.16	1.35	1.72	1.97	2.21	2.37	2.50	2.60	2.67	2.74	2.80	2.84	2.84	2.78
	1.50	0.27	0.48	0.77	0.99	1.20	1.39	1.79	2.04	2.30	2.48	2.61	2.73	2.80	2.88	2.95	3.01	3.02	2.97
	3.00	0.27	0.49	0.78	1.01	1.22	1.43	1.83	2.10	2.37	2.55	2.69	2.82	2.89	2.98	3.05	3.12	3.15	3.11
106	1.00	0.29	0.53	0.84	1.09	1.32	1.53	1.97	2.26	2.54	2.74	2.88	3.01	3.08	3.18	3.24	3.30	3.30	3.23
	1.05	0.29	0.53	0.86	1.10	1.34	1.56	2.01	2.30	2.60	2.80	2.95	3.08	3.16	3.26	3.33	3.39	3.41	3.34
	1.20	0.30	0.55	0.88	1.14	1.38	1.62	2.08	2.39	2.70	2.92	3.08	3.22	3.31	3.41	3.50	3.58	3.61	3.57
	1.50	0.31	0.56	0.90	1.17	1.42	1.66	2.14	2.46	2.79	3.01	3.18	3.33	3.42	3.54	3.63	3.72	3.77	3.74
	3.00	0.31	0.57	0.92	1.19	1.44	1.69	2.18	2.51	2.84	3.08	3.25	3.41	3.51	3.63	3.73	3.83	3.88	3.86
112	1.00	0.31	0.57	0.91	1.18	1.43	1.67	2.15	2.46	2.76	2.97	3.13	3.26	3.34	3.43	3.50	3.54	3.53	3.42
	1.05	0.32	0.58	0.93	1.20	1.45	1.69	2.18	2.50	2.82	3.03	3.20	3.33	3.41	3.51	3.58	3.64	3.63	3.54
	1.20	0.32	0.59	0.95	1.23	1.50	1.75	2.26	2.59	2.92	3.15	3.32	3.47	3.56	3.67	3.75	3.82	3.83	3.76
	1.50	0.33	0.60	0.97	1.26	1.53	1.79	2.32	2.66	3.01	3.24	3.43	3.58	3.68	3.80	3.89	3.97	3.99	3.93
	3.00	0.33	0.61	0.99	1.28	1.56	1.82	2.36	2.71	3.07	3.31	3.50	3.66	3.76	3.88	3.98	4.07	4.11	4.06
118	1.00	0.34	0.61	0.98	1.27	1.54	1.80	2.32	2.65	2.98	3.20	3.37	3.50	3.58	3.67	3.74	3.77	3.73	3.58
	1.05	0.34	0.62	1.00	1.29	1.57	1.83	2.35	2.70	3.03	3.26	3.43	3.58	3.66	3.75	3.82	3.86	3.83	3.69
	1.20	0.35	0.63	1.02	1.32	1.61	1.88	2.43	2.78	3.14	3.38	3.56	3.72	3.80	3.91	3.99	4.05	4.03	3.91
	1.50	0.35	0.64	1.04	1.35	1.64	1.92	2.49	2.85	3.22	3.47	3.66	3.83	3.92	4.04	4.13	4.19	4.19	4.09
	3.00	0.36	0.65	1.06	1.37	1.67	1.95	2.53	2.90	3.28	3.54	3.74	3.91	4.00	4.13	4.22	4.30	4.31	4.21
125	1.00	0.36	0.66	1.06	1.38	1.67	1.95	2.51	2.87	3.23	3.46	3.63	3.77	3.85	3.94	3.99	4.00	3.92	3.72
	1.05	0.37	0.67	1.08	1.40	1.70	1.98	2.55	2.92	3.28	3.52	3.70	3.85	3.93	4.02	4.08	4.10	4.02	3.83
	1.20	0.37	0.68	1.10	1.43	1.74	2.03	2.62	3.01	3.39	3.64	3.83	3.99	4.07	4.18	4.25	4.28	4.22	4.05
	1.50	0.38	0.69	1.12	1.46	1.77	2.08	2.68	3.08	3.47	3.73	3.93	4.10	4.19	4.30	4.38	4.43	4.39	4.23
	3.00	0.38	0.70	1.14	1.48	1.80	2.11	2.72	3.13	3.53	3.80	4.00	4.18	4.27	4.39	4.48	4.53	4.50	4.35
132	1.00	0.39	0.71	1.15	1.48	1.80	2.10	2.71	3.09	3.47	3.71	3.89	4.03	4.10	4.18	4.22	4.21	4.07	3.80
	1.05	0.39	0.72	1.16	1.50	1.82	2.13	2.74	3.14	3.52	3.77	3.95	4.10	4.18	4.26	4.31	4.30	4.17	3.91
	1.20	0.40	0.73	1.18	1.54	1.87	2.18	2.82	3.23	3.63	3.89	4.08	4.24	4.33	4.42	4.48	4.48	4.38	4.13
	1.50	0.41	0.74	1.20	1.56	1.90	2.23	2.88	3.30	3.71	3.98	4.18	4.35	4.44	4.55	4.61	4.63	4.54	4.31
	3.00	0.41	0.75	1.22	1.58	1.93	2.26	2.92	3.35	3.77	4.05	4.26	4.43	4.52	4.64	4.71	4.73	4.65	4.43
140	1.00	0.42	0.76	1.24	1.60	1.95	2.27	2.92	3.34	3.73	3.99	4.16	4.30	4.37	4.43	4.45	4.40	4.19	
	1.05	0.42	0.77	1.25	1.62	1.97	2.30	2.96	3.38	3.79	4.05	4.23	4.37	4.45	4.52	4.54	4.49	4.30	
	1.20	0.43	0.79	1.28	1.66	2.02	2.36	3.04	3.47	3.89	4.17	4.36	4.51	4.59	4.67	4.71	4.68	4.50	
	1.50	0.44	0.80	1.30	1.68	2.05	2.40	3.09	3.54	3.97	4.26	4.46	4.62	4.71	4.80	4.84	4.82	4.66	
	3.00	0.44	0.81	1.31	1.70	2.07	2.43	3.14	3.59	4.03	4.32	4.53	4.70	4.79	4.89	4.94	4.92	4.77	
150	1.00	0.46	0.83	1.35	1.75	2.13	2.49	3.19	3.63	4.05	4.31	4.49	4.61	4.67	4.71	4.69	4.57	4.26	
	1.05	0.46	0.84	1.36	1.77	2.15	2.51	3.23	3.68	4.10	4.37	4.55	4.69	4.75	4.79	4.78	4.67	4.37	
	1.20	0.47	0.86	1.39	1.80	2.20	2.57	3.30	3.77	4.21	4.49	4.68	4.83	4.89	4.95	4.95	4.85	4.57	
	1.50	0.47	0.87	1.41	1.83	2.23	2.61	3.36	3.84	4.29	4.58	4.78	4.94	5.01	5.07	5.08	5.00	4.73	
	3.00	0.48	0.88	1.42	1.85	2.26	2.64	3.40	3.89	4.35	4.65	4.86	5.01	5.09	5.16	5.18	5.10	4.84	
160	1.00	0.49	0.90	1.46	1.90	2.31	2.69	3.45	3.92	4.35	4.62	4.78	4.89	4.93	4.94	4.87	4.68		
	1.05	0.50	0.91	1.48	1.92	2.33	2.72	3.49	3.97	4.41	4.68	4.85	4.96	5.01	5.02	4.96	4.77		
	1.20	0.50	0.92	1.50	1.95	2.38	2.77	3.56	4.05	4.51	4.79	4.98	5.10	5.15	5.18	5.13	4.95		
	1.50	0.51	0.94	1.52	1.98	2.41	2.82	3.62	4.12	4.60	4.89	5.08	5.21	5.27	5.30	5.26	5.10		
	3.00	0.51	0.94	1.54	2.00	2.44	2.85	3.66	4.17	4.65	4.95	5.15	5.29	5.35	5.39	5.36	5.20		
v_{max}	m/s	40																	

Power capacity rating P_R for CONTI-V MULTIRIB® Belt – Section PL

Table 28

d_{bk} mm	i or 1:i	Rpm of the small pulley n_k (min ⁻¹)																	
		200	400	700	950	1200	1450	2000	2400	2850	3200	3500	3800	4000	4300	4600	5000	5500	6000
170	1.00	0.53	0.97	1.58	2.04	2.49	2.90	3.71	4.20	4.64	4.90	5.05	5.13	5.15	5.11	4.99			
	1.05	0.53	0.98	1.59	2.06	2.51	2.93	3.74	4.24	4.70	4.96	5.12	5.21	5.23	5.19	5.08			
	1.20	0.54	0.99	1.61	2.10	2.55	2.98	3.82	4.33	4.80	5.08	5.24	5.35	5.37	5.35	5.25			
	1.50	0.55	1.00	1.64	2.13	2.59	3.02	3.88	4.40	4.88	5.17	5.35	5.46	5.49	5.48	5.38			
	3.00	0.55	1.01	1.65	2.14	2.61	3.05	3.92	4.45	4.94	5.24	5.42	5.54	5.57	5.57	5.48			
180	1.00	0.56	1.04	1.69	2.19	2.66	3.10	3.95	4.46	4.91	5.16	5.29	5.34	5.33	5.23	5.05			
	1.05	0.57	1.04	1.70	2.21	2.68	3.13	3.99	4.51	4.97	5.22	5.35	5.41	5.40	5.32	5.13			
	1.20	0.58	1.06	1.73	2.24	2.73	3.18	4.06	4.60	5.07	5.33	5.48	5.55	5.55	5.47	5.30			
	1.50	0.58	1.07	1.75	2.27	2.76	3.22	4.12	4.67	5.15	5.43	5.58	5.66	5.67	5.60	5.44			
	3.00	0.59	1.08	1.76	2.29	2.79	3.25	4.16	4.72	5.21	5.49	5.66	5.74	5.75	5.69	5.53			
190	1.00	0.60	1.10	1.80	2.33	2.83	3.30	4.19	4.72	5.16	5.39	5.49	5.51	5.46	5.30				
	1.05	0.60	1.11	1.81	2.35	2.86	3.33	4.23	4.76	5.22	5.45	5.56	5.58	5.53	5.38				
	1.20	0.61	1.13	1.84	2.39	2.90	3.38	4.31	4.85	5.32	5.57	5.69	5.72	5.68	5.54				
	1.50	0.62	1.14	1.86	2.41	2.94	3.42	4.36	4.92	5.41	5.66	5.79	5.83	5.80	5.67				
	3.00	0.62	1.15	1.87	2.43	2.96	3.45	4.41	4.97	5.47	5.73	5.86	5.91	5.88	5.75				
200	1.00	0.64	1.17	1.91	2.47	3.00	3.50	4.43	4.96	5.40	5.60	5.67	5.63	5.54					
	1.05	0.64	1.18	1.92	2.49	3.03	3.52	4.47	5.01	5.45	5.66	5.73	5.70	5.62					
	1.20	0.65	1.19	1.95	2.53	3.07	3.58	4.54	5.10	5.56	5.78	5.86	5.84	5.76					
	1.50	0.65	1.21	1.97	2.56	3.11	3.62	4.60	5.17	5.64	5.87	5.96	5.95	5.88					
	3.00	0.66	1.21	1.98	2.58	3.13	3.65	4.64	5.22	5.70	5.94	6.04	6.03	5.96					
212	1.00	0.68	1.25	2.04	2.64	3.21	3.73	4.70	5.24	5.66	5.82	5.83	5.72						
	1.05	0.68	1.26	2.05	2.66	3.23	3.75	4.74	5.29	5.71	5.88	5.90	5.79						
	1.20	0.69	1.27	2.08	2.70	3.27	3.81	4.81	5.37	5.81	6.00	6.03	5.93						
	1.50	0.70	1.29	2.10	2.72	3.31	3.85	4.87	5.44	5.90	6.09	6.13	6.04						
	3.00	0.70	1.29	2.11	2.74	3.33	3.88	4.91	5.49	5.96	6.15	6.20	6.12						
224	1.00	0.78	1.45	2.38	3.10	3.77	4.39	5.56	6.22	6.74	6.95	6.99							
	1.05	0.78	1.46	2.39	3.11	3.78	4.40	5.58	6.25	6.77	6.99	7.04							
	1.20	0.79	1.47	2.40	3.13	3.81	4.44	5.63	6.31	6.84	7.07	7.12							
	1.50	0.79	1.47	2.42	3.15	3.83	4.47	5.67	6.35	6.90	7.13	7.19							
	3.00	0.80	1.48	2.43	3.16	3.85	4.49	5.70	6.39	6.94	7.18	7.24							
236	1.00	0.82	1.53	2.51	3.26	3.96	4.61	5.81	6.46	6.94	7.09	7.05							
	1.05	0.83	1.54	2.52	3.27	3.98	4.63	5.83	6.49	6.97	7.13	7.10							
	1.20	0.83	1.54	2.53	3.30	4.01	4.66	5.88	6.55	7.04	7.21	7.18							
	1.50	0.84	1.55	2.55	3.31	4.03	4.69	5.92	6.60	7.10	7.27	7.25							
	3.00	0.84	1.56	2.56	3.33	4.05	4.71	5.95	6.63	7.13	7.31	7.30							
250	1.00	0.87	1.62	2.66	3.45	4.19	4.86	6.08	6.72	7.13	7.19								
	1.05	0.88	1.63	2.66	3.46	4.20	4.88	6.11	6.75	7.16	7.23								
	1.20	0.88	1.64	2.68	3.49	4.23	4.91	6.16	6.81	7.23	7.31								
	1.50	0.88	1.64	2.69	3.50	4.25	4.94	6.20	6.85	7.29	7.37								
	3.00	0.89	1.65	2.70	3.52	4.27	4.96	6.22	6.89	7.33	7.41								
v_{max}	m/s	40																	

Power capacity rating P_R for CONTI-V MULTIRIB® Belt – section PM

Power capacity rating P_R (kW) for one rib as a function of the effective diameter of the small pulley d_{bk} , the transmission ratio i , the rpm of the small pulley n_k and the effective length $L_b = 4089$ mm.

Power capacity rating P_R for CONTI-V MULTIRIB® Belt – Section PM

Table 29

d_{bk} mm	i or 1:i	Rpm of the small pulley n_k (min ⁻¹)																	
		50	100	200	300	400	700	950	1200	1450	1600	1800	2000	2200	2400	2850	3200	3600	4000
180	1.00	0.35	0.63	1.12	1.57	1.98	3.10	3.92	4.65	5.28	5.62	6.01	6.34	6.60	6.78	6.89	6.67	6.04	4.98
	1.05	0.36	0.64	1.14	1.60	2.02	3.17	4.02	4.77	5.44	5.79	6.20	6.55	6.83	7.03	7.19	7.01	6.42	5.40
	1.20	0.37	0.66	1.18	1.66	2.11	3.32	4.22	5.02	5.74	6.12	6.58	6.97	7.28	7.53	7.78	7.67	7.16	6.23
	1.50	0.37	0.68	1.22	1.71	2.17	3.43	4.37	5.22	5.97	6.38	6.87	7.29	7.65	7.92	8.25	8.19	7.75	6.88
	3.00	0.38	0.69	1.24	1.74	2.22	3.52	4.48	5.36	6.14	6.57	7.08	7.53	7.90	8.20	8.58	8.56	8.17	7.35
190	1.00	0.38	0.68	1.22	1.71	2.17	3.41	4.32	5.13	5.84	6.21	6.65	7.01	7.29	7.48	7.57	7.29	6.53	
	1.05	0.38	0.69	1.24	1.74	2.21	3.49	4.42	5.26	5.99	6.38	6.84	7.22	7.52	7.73	7.87	7.62	6.91	
	1.20	0.39	0.71	1.28	1.81	2.30	3.63	4.62	5.51	6.29	6.71	7.21	7.63	7.97	8.23	8.46	8.29	7.65	
	1.50	0.40	0.73	1.32	1.86	2.36	3.74	4.77	5.70	6.53	6.98	7.51	7.96	8.33	8.62	8.93	8.81	8.24	
	3.00	0.41	0.74	1.34	1.89	2.41	3.83	4.89	5.84	6.70	7.16	7.71	8.19	8.59	8.90	9.26	9.18	8.66	
200	1.00	0.41	0.74	1.32	1.86	2.36	3.72	4.72	5.61	6.39	6.79	7.27	7.66	7.95	8.15	8.20	7.83	6.91	
	1.05	0.41	0.75	1.34	1.89	2.40	3.79	4.82	5.74	6.54	6.96	7.46	7.87	8.18	8.40	8.50	8.17	7.29	
	1.20	0.42	0.77	1.39	1.95	2.48	3.94	5.02	5.99	6.84	7.29	7.83	8.28	8.64	8.90	9.09	8.83	8.03	
	1.50	0.43	0.78	1.42	2.00	2.55	4.05	5.17	6.18	7.08	7.56	8.12	8.61	9.00	9.29	9.56	9.35	8.62	
	3.00	0.44	0.80	1.44	2.04	2.60	4.13	5.28	6.32	7.25	7.74	8.33	8.84	9.25	9.57	9.89	9.72	9.04	
224	1.00	0.60	1.08	1.96	2.76	3.51	5.57	7.09	8.43	9.59	10.19	10.88	11.43	11.82	12.05	11.90	11.09		
	1.05	0.60	1.09	1.98	2.80	3.57	5.66	7.21	8.59	9.78	10.40	11.12	11.69	12.11	12.36	12.28	11.51		
	1.20	0.61	1.12	2.03	2.88	3.67	5.84	7.46	8.90	10.16	10.82	11.58	12.21	12.68	12.98	13.01	12.33		
	1.50	0.63	1.14	2.07	2.94	3.75	5.99	7.65	9.14	10.45	11.15	11.95	12.62	13.13	13.47	13.60	12.99		
	3.00	0.63	1.16	2.10	2.98	3.81	6.09	7.79	9.32	10.66	11.38	12.21	12.91	13.45	13.82	14.01	13.45		
250	1.00	0.69	1.25	2.28	3.22	4.11	6.55	8.33	9.90	11.24	11.92	12.67	13.23	13.59	13.72	13.14			
	1.05	0.69	1.27	2.30	3.26	4.17	6.64	8.46	10.06	11.43	12.13	12.90	13.49	13.88	14.04	13.52			
	1.20	0.71	1.29	2.36	3.34	4.27	6.82	8.70	10.37	11.80	12.54	13.37	14.01	14.44	14.66	14.25			
	1.50	0.72	1.31	2.40	3.40	4.35	6.96	8.90	10.62	12.10	12.87	13.74	14.42	14.89	15.15	14.84			
	3.00	0.72	1.33	2.43	3.45	4.41	7.06	9.04	10.79	12.31	13.10	14.00	14.71	15.21	15.50	15.25			
280	1.00	0.79	1.45	2.65	3.75	4.80	7.65	9.73	11.53	13.03	13.76	14.53	15.05	15.29	15.23				
	1.05	0.80	1.46	2.67	3.79	4.85	7.74	9.86	11.69	13.22	13.97	14.77	15.31	15.58	15.54				
	1.20	0.81	1.49	2.72	3.87	4.95	7.92	10.10	12.00	13.59	14.38	15.24	15.83	16.15	16.16				
	1.50	0.82	1.51	2.77	3.93	5.04	8.07	10.30	12.25	13.89	14.71	15.60	16.24	16.60	16.65				
	3.00	0.83	1.52	2.79	3.98	5.09	8.17	10.43	12.42	14.10	14.94	15.86	16.53	16.92	17.00				
315	1.00	0.91	1.68	3.07	4.36	5.59	8.91	11.31	13.34	14.96	15.71	16.42	16.79	16.77					
	1.05	0.92	1.69	3.10	4.40	5.64	9.00	11.43	13.50	15.15	15.92	16.66	17.05	17.06					
	1.20	0.93	1.72	3.15	4.48	5.74	9.18	11.68	13.81	15.52	16.33	17.13	17.57	17.63					
	1.50	0.94	1.74	3.19	4.54	5.82	9.33	11.87	14.05	15.82	16.66	17.50	17.98	18.08					
	3.00	0.95	1.75	3.22	4.59	5.88	9.43	12.01	14.23	16.03	16.89	17.76	18.27	18.40					
355	1.00	1.05	1.93	3.55	5.05	6.47	10.31	13.03	15.26	16.93	17.63	18.17	18.23						
	1.05	1.06	1.95	3.58	5.09	6.53	10.40	13.16	15.42	17.13	17.85	18.41	18.49						
	1.20	1.07	1.97	3.63	5.17	6.63	10.58	13.40	15.73	17.50	16.26	18.88	19.01						
	1.50	1.08	1.99	3.67	5.23	6.71	10.73	13.60	15.98	17.80	18.59	19.25	19.42						
	3.00	1.09	2.01	3.70	5.28	6.77	10.83	13.73	16.15	18.01	18.82	19.51	19.71						
400	1.00	1.20	2.22	4.08	5.82	7.45	11.84	14.87	17.24	18.85	19.39	19.57							
	1.05	1.21	2.23	4.11	5.86	7.51	11.93	14.99	17.40	19.04	19.60	19.80							
	1.20	1.22	2.26	4.16	5.94	7.61	12.11	15.24	17.71	19.41	20.01	20.27							
	1.50	1.23	2.28	4.20	6.00	7.69	12.26	15.43	17.96	19.71	20.34	20.64							
	3.00	1.24	2.29	4.23	6.04	7.75	12.36	15.57	18.13	19.92	20.57	20.90							
450	1.00	1.37	2.53	4.67	6.66	8.52	13.47	16.78	19.19	20.54	20.77								
	1.05	1.37	2.54	4.70	6.69	8.58	13.56	16.90	19.35	20.73	20.98								
	1.20	1.39	2.57	4.75	6.77	8.68	13.75	17.15	19.66	21.11	21.40								
	1.50	1.40	2.59	4.79	6.83	8.76	13.89	17.34	19.90	21.40	21.72								
	3.00	1.40	2.61	4.82	6.88	8.82	13.99	17.48	20.08	21.61	21.95								
500	1.00	1.53	2.84	5.25	7.48	9.57	15.04	18.53	20.84	21.74									
	1.05	1.54	2.86	5.27	7.52	9.63	15.13	18.66	21.00	21.93									
	1.20	1.55	2.88	5.33	7.60	9.73	15.31	18.90	21.31	22.31									
	1.50	1.56	2.90	5.37	7.66	9.81	15.45	19.10	21.56	22.60									
	3.00	1.57	2.92	5.40	7.70	9.87	15.55	19.23	21.73	22.81									
560	1.00	1.90	3.53	6.53	9.30	11.88	18.49	22.45	24.64										
	1.05	1.91	3.55	6.55	9.34	11.94	18.59	22.59	24.82										
	1.20	1.92	3.57	6.61	9.43	12.05	18.79	22.86	25.16										
	1.50	1.94	3.60	6.66	9.49	12.14	18.95	23.07	25.43										
	3.00	1.94	3.61	6.69	9.54	12.21	19.06	23.22	25.62										
v_{max}	m/s								35										

Power capacity rating P_R for CONTI-V MULTIRIB® Belt – Section PM

Table 29

d_{bk} mm	i or 1:i	Rpm of the small pulley n_k (min ⁻¹)																				
		50	100	200	300	400	700	950	1200	1450	1600	1800	2000	2200	2400	2850	3200	3600	4000			
630	1.00	2.15	4.00	7.39	10.52	13.42	20.62	24.51														
	1.05	2.16	4.01	7.42	10.57	13.48	20.72	24.65														
	1.20	2.17	4.04	7.48	10.65	13.59	20.92	24.92														
	1.50	2.18	4.06	7.52	10.72	13.68	21.07	25.13														
	3.00	2.19	4.08	7.56	10.77	13.75	21.19	25.28														
710	1.00	2.43	4.53	8.37	11.89	15.13	22.82	26.34														
	1.05	2.44	4.54	8.40	11.94	15.18	22.92	26.47														
	1.20	2.46	4.57	8.46	12.02	15.30	23.12	26.74														
	1.50	2.47	4.59	8.50	12.09	15.39	23.28	26.96														
	3.00	2.48	4.61	8.53	12.14	15.45	23.39	27.11														
800	1.00	2.75	5.11	9.45	13.40	16.97	24.99															
	1.05	2.76	5.13	9.48	13.44	17.03	25.09															
	1.20	2.77	5.16	9.54	13.53	17.14	25.29															
	1.50	2.78	5.18	9.58	13.59	17.23	25.45															
	3.00	2.79	5.20	9.61	13.64	17.29	25.56															
1000	1.00	3.44	6.40	11.78	16.59	20.77	28.47															
	1.05	3.44	6.41	11.81	16.63	20.82	28.57															
	1.20	3.46	6.44	11.87	16.72	20.94	28.77															
	1.50	3.47	6.46	11.91	16.78	21.03	28.93															
	3.00	3.48	6.48	11.95	16.83	21.09	29.04															
v_{max}	m/s																	35				

Power capacity rating P_R for CONTI-V MULTIRIB® Belt – section PL, ZAR type

Power capacity rating P_R (kW) for one rib as a function of the effective diameter of the small pulley d_{bk}, the transmission ratio i, the rpm of the small pulley n_k and the effective length L_b = 2096 mm.

Power capacity rating P_R for CONTI-V MULTIRIB® Belt – Section PL, ZAR type Table 30

Table with columns for d_{bk} mm, i or 1:i, and Rpm of the small pulley n_k (min⁻¹) from 200 to 6000. Rows represent different pulley diameters from 75 to 160 mm. Each cell contains a numerical value for power capacity rating.

Power capacity rating P_R for CONTI-V MULTIRIB® Belt – Section PL, ZAR type

Table 30

d_{bk} mm	i or 1:i	Rpm of the small pulley n_k (min ⁻¹)																	
		200	400	700	950	1200	1450	2000	2400	2850	3200	3500	3800	4000	4300	4600	5000	5500	6000
170	1.00	0.79	1.45	2.36	3.07	3.73	4.35	5.56	6.30	6.96	7.35	7.57	7.70	7.73	7.67	7.49			
	1.05	0.80	1.47	2.38	3.09	3.76	4.39	5.62	6.36	7.04	7.44	7.67	7.81	7.84	7.79	7.62			
	1.20	0.81	1.49	2.42	3.15	3.83	4.47	5.73	6.50	7.20	7.61	7.87	8.02	8.06	8.03	7.87			
	1.50	0.82	1.51	2.45	3.19	3.88	4.53	5.81	6.60	7.32	7.75	8.02	8.19	8.24	8.21	8.07			
	3.00	0.82	1.52	2.47	3.22	3.92	4.58	5.88	6.68	7.41	7.85	8.13	8.30	8.36	8.35	8.22			
180	1.00	0.85	1.56	2.53	3.28	3.99	4.65	5.93	6.70	7.37	7.74	7.93	8.01	7.99	7.85	7.57			
	1.05	0.85	1.57	2.55	3.31	4.02	4.69	5.99	6.76	7.45	7.83	8.03	8.12	8.10	7.97	7.70			
	1.20	0.86	1.59	2.59	3.36	4.09	4.77	6.10	6.90	7.61	8.00	8.22	8.33	8.32	8.21	7.96			
	1.50	0.87	1.61	2.63	3.42	4.16	4.86	6.21	7.04	7.77	8.19	8.43	8.55	8.56	8.46	8.22			
	3.00	0.88	1.62	2.64	3.43	4.18	4.88	6.25	7.08	7.82	8.24	8.48	8.61	8.62	8.53	8.30			
190	1.00	0.90	1.66	2.70	3.50	4.25	4.95	6.29	7.08	7.75	8.09	8.24	8.26	8.19	7.95				
	1.05	0.91	1.67	2.72	3.53	4.28	4.99	6.35	7.15	7.83	8.18	8.34	8.36	8.30	8.07				
	1.20	0.92	1.69	2.75	3.58	4.35	5.07	6.46	7.28	7.98	8.35	8.53	8.57	8.52	8.31				
	1.50	0.93	1.71	2.79	3.62	4.40	5.13	6.55	7.38	8.11	8.49	8.69	8.74	8.70	8.50				
	3.00	0.93	1.72	2.81	3.65	4.44	5.18	6.61	7.46	8.20	8.59	8.79	8.86	8.82	8.63				
200	1.00	0.95	1.76	2.86	3.71	4.51	5.24	6.64	7.45	8.10	8.40	8.50	8.44	8.31					
	1.05	0.96	1.77	2.88	3.74	4.54	5.28	6.70	7.51	8.18	8.49	8.60	8.55	8.42					
	1.20	0.97	1.79	2.92	3.79	4.61	5.36	6.81	7.65	8.34	8.67	8.79	8.76	8.65					
	1.50	0.98	1.81	2.95	3.83	4.66	5.43	6.90	7.75	8.46	8.81	8.95	8.93	8.82					
	3.00	0.99	1.82	2.97	3.86	4.70	5.47	6.96	7.82	8.55	8.91	9.06	9.05	8.94					
212	1.00	1.02	1.88	3.06	3.97	4.81	5.59	7.05	7.86	8.48	8.73	8.75	8.58						
	1.05	1.02	1.89	3.08	3.99	4.84	5.63	7.11	7.93	8.56	8.82	8.85	8.69						
	1.20	1.04	1.91	3.12	4.04	4.91	5.71	7.22	8.06	8.72	8.99	9.04	8.90						
	1.50	1.04	1.93	3.15	4.09	4.96	5.77	7.30	8.17	8.85	9.13	9.19	9.07						
	3.00	1.05	1.94	3.17	4.12	5.00	5.82	7.37	8.24	8.93	9.23	9.30	9.18						
224	1.00	1.17	2.18	3.57	4.64	5.65	6.58	8.34	9.33	10.11	10.43	10.49							
	1.05	1.18	2.18	3.58	4.66	5.67	6.61	8.38	9.38	10.16	10.49	10.56							
	1.20	1.18	2.20	3.61	4.70	5.71	6.66	8.45	9.46	10.26	10.61	10.68							
	1.50	1.19	2.21	3.63	4.72	5.75	6.70	8.51	9.53	10.35	10.70	10.78							
	3.00	1.19	2.22	3.64	4.74	5.77	6.73	8.55	9.58	10.40	10.76	10.86							
236	1.00	1.24	2.30	3.76	4.89	5.94	6.91	8.71	9.69	10.41	10.63	10.58							
	1.05	1.24	2.30	3.77	4.91	5.97	6.94	8.75	9.74	10.46	10.69	10.64							
	1.20	1.25	2.32	3.80	4.94	6.01	6.99	8.82	9.82	10.56	10.81	10.77							
	1.50	1.25	2.33	3.82	4.97	6.04	7.03	8.88	9.89	10.64	10.90	10.87							
	3.00	1.26	2.34	3.83	4.99	6.07	7.06	8.92	9.94	10.70	10.97	10.94							
250	1.00	1.31	2.43	3.98	5.18	6.28	7.29	9.13	10.08	10.69	10.79	10.58							
	1.05	1.31	2.44	4.00	5.19	6.30	7.32	9.16	10.12	10.75	10.85								
	1.20	1.32	2.45	4.02	5.23	6.35	7.37	9.24	10.21	10.85	10.96								
	1.50	1.33	2.47	4.04	5.26	6.38	7.41	9.29	10.28	10.93	11.06								
	3.00	1.33	2.47	4.06	5.27	6.40	7.44	9.33	10.33	10.99	11.12								
v_{max}	m/s	40																	

Power capacity rating P_R for CONTI-V MULTIRIB® Belt – section PM, ZAR type

Power capacity rating P_R (kW) for one rib as a function of the effective diameter of the small pulley d_{bk} , the transmission ratio i , the rpm of the small pulley n_k and the effective length $L_b = 4098$ mm.

Power capacity rating P_R for CONTI-V MULTIRIB® Belt – Section PM, ZAR type

Table 31

d_{bk} mm	i or 1:i	Rpm of the small pulley n_k (min ⁻¹)																	
		50	100	200	300	400	700	950	1200	1450	1600	1800	2000	2200	2400	2850	3200	3600	4000
180	1.00	0.53	0.94	1.68	2.35	2.97	4.65	5.88	6.97	7.93	8.43	9.02	9.51	9.90	10.17	10.34	10.00	9.06	7.47
	1.05	0.53	0.96	1.71	2.40	3.04	4.76	6.03	7.16	8.16	8.69	9.31	9.83	10.25	10.55	10.79	10.51	9.63	8.10
	1.20	0.55	0.99	1.77	2.49	3.16	4.98	6.33	7.53	8.61	9.18	9.86	10.45	10.93	11.29	11.67	11.50	10.75	9.34
	1.50	0.56	1.01	1.82	2.56	3.26	5.15	6.56	7.83	8.96	9.57	10.31	10.94	11.47	11.88	12.37	12.29	11.63	10.32
	3.00	0.57	1.03	1.86	2.62	3.33	5.27	6.72	8.04	9.21	9.85	10.62	11.29	11.85	12.30	12.87	12.84	12.26	11.02
190	1.00	0.57	1.02	1.83	2.57	3.26	5.12	6.48	7.70	8.76	9.32	9.97	10.51	10.93	11.22	11.36	10.93	9.79	
	1.05	0.58	1.04	1.86	2.62	3.32	5.23	6.63	7.89	8.99	9.57	10.26	10.83	11.28	11.60	11.81	11.44	10.36	
	1.20	0.59	1.07	1.93	2.71	3.44	5.45	6.93	8.26	9.44	10.07	10.82	11.45	11.96	12.35	12.70	12.43	11.48	
	1.50	0.60	1.09	1.98	2.78	3.54	5.62	7.16	8.56	9.80	10.46	11.26	11.94	12.50	12.93	13.40	13.21	12.36	
	3.00	0.61	1.11	2.01	2.84	3.61	5.74	7.33	8.76	10.05	10.74	11.57	12.29	12.88	13.35	13.89	13.77	12.99	
200	1.00	0.61	1.10	1.98	2.79	3.54	5.58	7.08	8.42	9.58	10.19	10.90	11.48	11.93	12.22	12.30	11.74	10.36	
	1.05	0.62	1.12	2.02	2.83	3.60	5.69	7.23	8.61	9.81	10.45	11.19	11.80	12.27	12.60	12.75	12.25	10.93	
	1.20	0.63	1.15	2.08	2.93	3.73	5.91	7.53	8.98	10.26	10.94	11.75	12.42	12.96	13.35	13.64	13.24	12.05	
	1.50	0.65	1.18	2.13	3.00	3.82	6.08	7.76	9.27	10.62	11.33	12.19	12.91	13.50	13.94	14.34	14.03	12.93	
	3.00	0.66	1.19	2.16	3.05	3.89	6.20	7.93	9.48	10.87	11.61	12.50	13.26	13.88	14.35	14.83	14.59	13.56	
224	1.00	0.89	1.62	2.93	4.14	5.27	8.36	10.63	12.64	14.38	15.29	16.32	17.14	17.73	18.07	17.85	16.63		
	1.05	0.90	1.64	2.97	4.20	5.35	8.50	10.82	12.88	14.67	15.61	16.68	17.53	18.16	18.54	18.41	17.26		
	1.20	0.92	1.68	3.05	4.31	5.50	8.77	11.19	13.35	15.23	16.23	17.37	18.31	19.01	19.47	19.52	18.50		
	1.50	0.94	1.71	3.11	4.41	5.63	8.98	11.48	13.71	15.68	16.72	17.93	18.92	19.69	20.21	20.39	19.48		
	3.00	0.95	1.73	3.16	4.47	5.71	9.13	11.68	13.98	15.99	17.07	18.32	19.36	20.17	20.73	21.01	20.18		
250	1.00	1.03	1.88	3.42	4.83	6.17	9.82	12.50	14.85	16.85	17.87	19.00	19.84	20.38	20.58	19.71			
	1.05	1.04	1.90	3.46	4.89	6.25	9.96	12.69	15.09	17.14	18.19	19.36	20.24	20.81	21.06	20.28			
	1.20	1.06	1.94	3.53	5.01	6.41	10.23	13.06	15.55	17.70	18.81	20.05	21.01	21.67	21.99	21.38			
	1.50	1.07	1.97	3.60	5.10	6.53	10.44	13.35	15.92	18.15	19.30	20.61	21.63	22.32	22.73	22.26			
	3.00	1.09	1.99	3.64	5.17	6.62	10.60	13.55	16.18	18.46	19.65	21.00	22.06	22.84	23.25	22.88			
280	1.00	1.19	2.17	3.97	5.63	7.20	11.48	14.60	17.30	19.54	20.64	21.80	22.57	22.93	22.84				
	1.05	1.20	2.19	4.01	5.69	7.28	11.61	14.78	17.54	19.83	20.96	22.16	22.97	23.37	23.31				
	1.20	1.22	2.23	4.09	5.81	7.43	11.88	15.15	18.00	20.39	21.58	22.85	23.74	24.22	24.24				
	1.50	1.23	2.26	4.15	5.90	7.55	12.10	15.44	18.37	20.83	22.07	23.41	24.36	24.90	24.98				
	3.00	1.24	2.29	4.19	5.96	7.64	12.25	15.65	18.63	21.15	22.42	23.80	24.79	25.37	25.50				
315	1.00	1.37	2.51	4.61	6.55	8.38	13.36	16.96	20.01	22.43	23.56	24.64	25.19	25.16					
	1.05	1.38	2.53	4.65	6.61	8.46	13.50	17.15	20.24	22.72	23.88	24.99	25.58	25.59					
	1.20	1.40	2.57	4.72	6.72	8.61	13.77	17.52	20.71	23.28	24.50	25.69	26.36	26.45					
	1.50	1.41	2.60	4.79	6.81	8.74	13.99	17.81	21.08	23.73	24.99	26.24	26.97	27.12					
	3.00	1.42	2.63	4.83	6.88	8.82	14.14	18.01	21.34	24.04	25.34	26.64	27.41	27.60					
355	1.00	1.57	2.90	5.33	7.58	9.71	15.47	19.55	22.89	25.40	26.45	27.26	27.34						
	1.05	1.58	2.92	5.37	7.64	9.79	15.61	19.73	23.13	25.69	26.77	27.62	27.73						
	1.20	1.60	2.96	5.44	7.76	9.94	15.88	20.10	23.60	26.25	27.39	28.32	28.51						
	1.50	1.62	2.99	5.50	7.85	10.07	16.09	20.39	23.97	26.70	27.88	28.87	29.12						
	3.00	1.63	3.01	5.55	7.91	10.15	16.24	20.60	24.23	27.01	28.23	29.26	29.56						
400	1.00	1.80	3.33	6.13	8.73	11.18	17.76	22.30	25.86	28.27	29.08	29.35							
	1.05	1.81	3.35	6.17	8.79	11.26	17.90	22.49	26.10	28.56	29.40	29.70							
	1.20	1.83	3.39	6.24	8.90	11.41	18.17	22.86	26.57	29.12	30.02	30.40							
	1.50	1.85	3.42	6.30	8.99	11.54	18.38	23.15	26.93	29.56	30.51	30.96							
	3.00	1.86	3.44	6.35	9.06	11.62	18.54	23.36	27.20	29.88	30.86	31.35							
450	1.00	2.05	3.80	7.00	9.98	12.78	20.21	25.16	28.78	30.81	31.16								
	1.05	2.06	3.82	7.04	10.04	12.86	20.35	25.35	29.02	31.10	31.47								
	1.20	2.08	3.86	7.12	10.16	13.02	20.62	25.72	29.48	31.66	32.09								
	1.50	2.10	3.89	7.18	10.25	13.14	20.83	26.01	29.85	32.10	32.58								
	3.00	2.11	3.91	7.23	10.32	13.23	20.99	26.22	30.11	32.42	32.93								
500	1.00	2.30	4.26	7.87	11.22	14.36	22.55	27.79	31.26	32.61									
	1.05	2.31	4.28	7.91	11.28	14.44	22.69	27.98	31.50	32.90									
	1.20	2.33	4.32	7.99	11.40	14.59	22.96	28.35	31.97	33.46									
	1.50	2.34	4.35	8.05	11.49	14.72	23.18	28.64	32.34	33.90									
	3.00	2.36	4.37	8.09	11.55	14.80	23.33	28.85	32.60	34.22									
560	1.00	2.85	5.30	9.79	13.94	17.82	27.74	33.67	36.96										
	1.05	2.86	5.32	9.83	14.01	17.91	27.89	33.88	37.22										
	1.20	2.89	5.36	9.92	14.14	18.08	28.19	34.29	37.73										
	1.50	2.90	5.39	9.98	14.24	18.22	28.42	34.61	38.14										
	3.00	2.91	5.42	10.03	14.31	18.31	28.59	34.83	38.43										
v_{max}	m/s								35										

Power capacity rating P_R for CONTI-V MULTIRIB® Belt – Section PM, ZAR type

Table 31

d_{bk} mm	i or 1:i	Rpm of the small pulley n_k (min ⁻¹)																	
		50	100	200	300	400	700	950	1200	1450	1600	1800	2000	2200	2400	2850	3200	3600	4000
630	1.00	3.23	6.00	11.09	15.78	20.13	30.92	36.76											
	1.05	3.24	6.02	11.13	15.85	20.22	31.08	36.97											
	1.20	3.26	6.06	11.22	15.98	20.39	31.38	37.37											
	1.50	3.28	6.10	11.29	16.08	20.52	31.61	37.69											
	3.00	3.29	6.12	11.33	16.15	20.62	31.78	37.92											
710	1.00	3.65	6.79	12.55	17.84	22.69	34.23	39.51											
	1.05	3.66	6.81	12.60	17.91	22.77	34.38	39.71											
	1.20	3.68	6.85	12.68	18.03	22.95	34.68	40.12											
	1.50	3.70	6.89	12.75	18.14	23.08	34.92	40.44											
	3.00	3.71	6.91	12.80	18.21	23.18	35.09	40.67											
800	1.00	4.12	7.67	14.17	20.10	25.45	37.48												
	1.05	4.13	7.69	14.22	20.16	25.54	37.63												
	1.20	4.15	7.74	14.30	20.29	25.71	37.93												
	1.50	4.17	7.77	14.37	20.39	25.85	38.17												
	3.00	4.18	7.79	14.42	20.46	25.94	38.34												
1000	1.00	5.15	9.59	17.68	24.88	31.15	42.70												
	1.05	5.16	9.61	17.72	24.95	31.24	42.85												
	1.20	5.19	9.66	17.80	25.07	31.41	43.15												
	1.50	5.20	9.69	17.87	25.18	31.54	43.39												
	3.00	5.21	9.71	17.92	25.25	31.64	43.56												
v_{max}	m/s	35																	

Examples of design procedure steps Drive with two pulleys

Driver:	Three-phase AC motor with normal starting torque	$P = 3.70 \text{ kW}$ $n_1 = 2850 \text{ min}^{-1}$
Driven machine:	Grinder	$n_2 = 8550 \text{ min}^{-1}$
Service conditions:	Effective diameter of large pulley Centre distance as required. Operations for 16 hours per day.	$d_{bg} \leq 125$

Service factor

c_2 from Table 20, page 25

$$c_2 = 1.2$$

Belt section

Fig. 5, page 26

selected: CONTI-V MULTIRIB® Belt – section PJ

Transmission ratio

$$i = \frac{n_1}{n_2}$$

$$i = \frac{2850}{8550} = 0.33$$

Effective diameter of pulleys

$$d_{b1} = d_{bg}$$

$$d_{b2} = d_{bk} = d_{bg} \cdot i + 2 \cdot h_b \cdot (i - 1)$$

h_b from Table 6, page 14

selected: $d_{bg} = 125 \text{ mm}$

$$d_{bk} = 125 \cdot 0.33 + 2 \cdot 1.20 \cdot (0.33 - 1) = 40 \text{ mm}$$

Centre distance

$$a_{\max} \leq 2 \cdot (d_{bg} + d_{bk})$$

$$a_{\min} \geq 0.7 \cdot (d_{bg} + d_{bk})$$

$$a_{\max} \leq 2 \cdot (125 + 40) = 330 \text{ mm}$$

$$a_{\min} \geq 0.7 \cdot (125 + 40) = 115.5 \text{ mm}$$

selected: $a \approx 220 \text{ mm}$

Effective length

$$L_b \approx 2 \cdot a + \frac{\pi}{2} (d_{bg} + d_{bk}) + \frac{(d_{bg} - d_{bk})^2}{4 \cdot a}$$

See Table 2, page 8

to determine the available effective length

$$L_b \approx 2 \cdot 220 + \frac{\pi}{2} (125 + 40) + \frac{(125 - 40)^2}{4 \cdot 220} \approx 707 \text{ mm}$$

selected: $L_b = 711 \text{ mm}$

Centre distance

This is determined according to the selected effective length

$$a \approx \frac{1}{4} \cdot \left(L_b - \frac{d_{bg} + d_{bk}}{2} \cdot \pi \right)$$

$$+ \frac{1}{4} \cdot \sqrt{\left(L_b - \frac{d_{bg} + d_{bk}}{2} \cdot \pi \right)^2 - 2 \cdot (d_{bg} - d_{bk})^2}$$

$$a \approx \frac{1}{4} \cdot \left(711 - \frac{125 + 40}{2} \cdot \pi \right)$$

$$+ \frac{1}{4} \cdot \sqrt{\left(711 - \frac{125 + 40}{2} \cdot \pi \right)^2 - 2 \cdot (125 - 40)^2}$$

$$= 221.84 \text{ mm}$$

Arc of contact around the small pulley

$$\beta = 2 \cdot \arccos \left(\frac{d_{bg} - d_{bk}}{2 \cdot a} \right)$$

$$\beta = 2 \cdot \arccos \left(\frac{125 - 40}{2 \cdot 221.84} \right) = 157.91^\circ$$

Take-up and installation allowances x und y

$$x = \frac{0.008 \cdot L_b}{\sin \frac{\beta}{2}}$$

$$x = \frac{0.008 \cdot 711}{\sin \frac{157.91}{2}} \approx 6 \text{ mm}$$

$$y = \frac{0.005 \cdot L_b + \pi \cdot h_f \cdot \frac{\beta}{360}}{\sin \frac{\beta}{2}}$$

$$y = \frac{0.005 \cdot 711 + \pi \cdot 2.5 \cdot \frac{157.91}{360}}{\sin \frac{157.91}{2}} \approx 7 \text{ mm}$$

h_f from Table 22, page 28

Belt speed

$$v = \frac{\pi \cdot (d_b + 2 \cdot h_b) \cdot n}{60 \cdot 10^3}$$

$$v = \frac{\pi \cdot (125 + 2 \cdot 1.2) \cdot 2850}{60 \cdot 10^3} = 19 \text{ m/s}$$

Flex frequency

$$f_B = \frac{10^3 \cdot v \cdot k}{L_b + 2 \cdot \pi \cdot h_b}$$

$$f_B = \frac{10^3 \cdot 19 \cdot 2}{711 + 2 \cdot \pi \cdot 1.2} = 52.9 \text{ s}^{-1}$$

Power correction factor for arc of contact

c_1 from Table 19, page 24

$$c_1 = 0.94$$

Length factor

c_3 from Table 21, page 25

$$c_3 = 0.92$$

Power capacity rating per rib

P_R from Table 26, page 34/35

$$P_R = 0.88 \text{ kW}$$

Number of ribs required

$$z_{er} = \frac{P \cdot c_2}{P_R \cdot c_1 \cdot c_3}$$

$$z_{er} = \frac{3.7 \cdot 1.2}{0.88 \cdot 0.94 \cdot 0.92} = 5,8$$

design choice:
CONTI-V MULTIRIB® Belt 6 PJ 711

Check the service factor

$$c_{2er} = z \cdot \frac{P_R \cdot c_1 \cdot c_3}{P}$$

$$c_{2er} = 6 \cdot \frac{0.88 \cdot 0.94 \cdot 0.92}{3.7} = 1.23$$

Effective pull

$$F_u = \frac{P \cdot 10^3}{v}$$

$$F_u = \frac{3700}{19} = 195 \text{ N}$$

Total span tension

$$F_v = (k_1 \cdot F_u + 2 \cdot k_2 \cdot v_2 \cdot z) \cdot \sin \frac{\beta}{2}$$

$$F_v = (1.84 \cdot 195 + 2 \cdot 0.009 \cdot 19^2 \cdot 6) \cdot \sin \frac{157.91}{2}$$

$$F_v = 390.4 \text{ N}$$

k_1 from Table 23, page 30

$$k_1 = 1.84$$

k_2 from Table 24, page 30

$$k_2 = 0.009$$

Check the installation tension of the Multiple V-Ribbed Belt

Static tension per rib

$$F = \frac{F_v}{2 \cdot z \cdot \sin \frac{\beta}{2}}$$

See Fig. 7, page 31 for force applied per rib

$$F_{\text{eges}} = z \cdot F_e$$

Installation tension value from Fig. 7, page 31

$$\frac{t_e}{L_f} \cdot 100$$

Free span length

$$L_f = a \cdot \sin \frac{\beta}{2}$$

Deflection of the belt

$$t_e = \frac{L_f}{100} \cdot \text{installation tension value}$$

$$F = \frac{390.4}{2 \cdot 6 \cdot \sin \frac{157.91}{2}} = 33.2 \text{ N}$$

$$F_e = 10 \text{ N}$$

$$F_{\text{eges}} = 6 \cdot 10 = 60 \text{ N}$$

$$\frac{t_e}{L_f} \cdot 100 = 5.2$$

$$L_f = 221.84 \cdot \sin \frac{157.91}{2} = 217.73 \text{ mm}$$

$$t_e = \frac{217.73}{100} \cdot 5.2 = 11.3 \text{ mm}$$

With this deflection, the belt installation tension is in conformity with the theoretical desired value.

Calculation of a multi-grooved/flat pulley drive

For drives with a transmission ratio of $i \geq 3$ and with an arc of contact of 120° to 150° around the small pulley it is possible to use a non-grooved pulley, i.e. a flat pulley, as the larger pulley.

The belt adhesion on a flat or on a grooved pulley is similar for an arc of contact of 133° . For a greater arc of contact the adhesion on the flat pulley is greater than on the grooved pulley.

When selecting the centre distance the following value is recommended:

$$a \approx \frac{d_{bF} - d_{bk}}{0.85} \qquad a_{\min} = d_{bF}$$

For drive calculations the same power ratings and service factors apply as to drives with two grooved pulleys. The power correction factors c_{1F} for arc of contact to be considered for multi-grooved/flat pulley drives are shown in Table 32 below.

Power correction factor c_{1F} for arc of contact

Table 32

Arc of contact β °(degrees)	Power correction factor c_{1F}	Arc of contact β °(degrees)	Power correction factor c_{1F}
150	0.82	133	0.86
148	0.83	130	0.86
145	0.83	127	0.85
142	0.84	123	0.84
139	0.85	120	0.82
136	0.85		

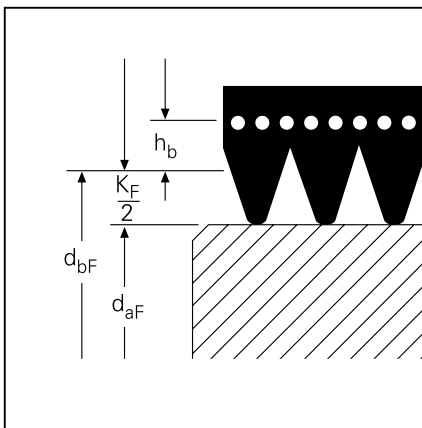

Effective diameter
of a flat pulley

Fig. 9

Effective length

The length is calculated taking account of the effective diameter concerned. For multi-grooved/flat pulley drives the actual effective diameter of the flat driven pulley has to be determined by adding the section – dependent adjustment value K_F to the outside diameter. The adjustment values concerned are shown in Table 33 below.

The effective diameter of the flat pulley is:

$$d_{bF} = d_{aF} + K_F$$

Adjustment value for effective diameter

Table 33

Section code	PH	PJ	PK	PL	PM
Adjustment value K_F	1.8	3.5	5.2	9.7/6.3*	15.3
Effective line differential h_b	0.8	1.2	1.5	3.0	4.0

*Values for truncated type.

The effective length is calculated using the following formula:

$$L_b \approx 2 \cdot a + \frac{\pi}{2} (d_{bF} + d_{bk}) + \frac{(d_{bF} - d_{bk})^2}{4 \cdot a}$$

Flat pulley width

The flat pulley should be wider than the Multiple V-Ribbed Belt.
The following recommendation applies:

$$b_F = (z + 2) \cdot s$$

z _____ number of ribs

s _____ rib spacing

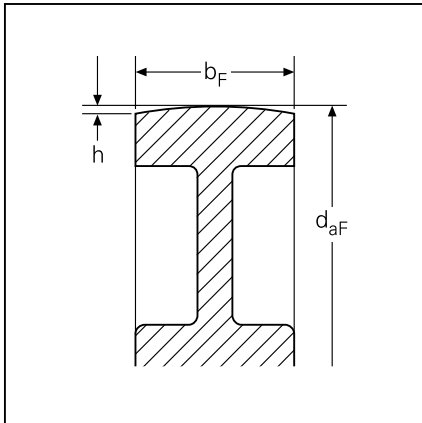

Curvature on a flat pulley

Fig. 10

Flat pulley shape

The flat pulley may be cylindrical or slightly convex (barrel-shaped). The curvature should not exceed 1 mm per 100 mm of outside diameter. Notes on flat pulleys are contained in DIN 111.

Curvature h (measurements in mm)

Table 34

Outside diameter d_{aF}	Curvature h for pulley face width	
	< 250	> 250
≤ 112	0.3	0.3
> 112–140	0.4	0.4
> 140–180	0.5	0.5
> 180–224	0.6	0.6
> 224–335	0.8	0.8
> 335–500	1.0	1.0
> 500–710	1.2	1.2
> 710–1000	1.2	1.5
> 1000–1400	1.5	2.0
> 1400–2000	1.8	2.5

Examples of design procedure steps

Drive with multi-groove/flat pulleys

Driver:	Electric motor with normal starting torque	$P = 10 \text{ kW}$ $n_1 = 700 \text{ min}^{-1}$
Driven machine:	Excentric press	$n_2 = 135 \text{ min}^{-1}$
Service conditions:	Diameter of flywheel Operations for 16 hours per day	$d_{aF} = 600$

Service factor

c_2 from Table 20, page 25

$$c_2 = 1.3$$

Belt section

Fig. 5, page 26

selected: CONTI-V MULTIRIB® Belt
section PL ZAR type

Transmission ratio

$$i = \frac{n_1}{n_2} = \frac{d_{w2}}{d_{w1}}$$

$$i = \frac{700}{135} = 5.2$$

Pitch diameter of pulleys

$$d_{wF} = d_{aF} + K_F + 2 \cdot h_b$$

K_F and h_b from Table 33, page 49

$$d_{wK} = \frac{d_{wF}}{i}$$

$$d_{wF} = 600 + 5.5 + 2 \cdot 3 = 611.5 \text{ mm}$$

$$d_{wK} = \frac{611.5}{5.2} = 117.6 \text{ mm}$$

Effective diameter of pulleys

$$d_{bF} = d_{aF} + K_F$$

$$d_{bK} = d_{wK} - 2 \cdot h_b$$

$$d_{bF} = 600 + 5.5 = 605.5 \text{ mm}$$

$$d_{bK} = 117.6 - 2 \cdot 3 = 111.6 \text{ mm}$$

selected: $d_{bK} = 112 \text{ mm}$
 $d_{wK} = 118 \text{ mm}$

Centre distance recommendation

$$a = \frac{d_{bF} - d_{bK}}{0.85}$$

$$a_{\min} = d_{bF}$$

$$a = \frac{605.5 - 112}{0.85} = 581 \text{ mm}$$

selected: $a = a_{\min} = d_{bF} \approx 606 \text{ mm}$

Effective length

$$L_b \approx 2 \cdot a + \frac{\pi}{2} (d_{bF} + d_{bK}) + \frac{(d_{bF} - d_{bK})^2}{4 \cdot a}$$

See Table 2, page 8

to determine the available effective length

$$L_b \approx 2 \cdot 606 + \frac{\pi}{2} (605.5 + 112) + \frac{(605.5 - 112)^2}{4 \cdot 606}$$

$$\approx 2440 \text{ mm}$$

selected: $L_b = 2477 \text{ mm}$

3 Calculation of Multiple V-Ribbed Belt drives

Centre distance

This is determined according to the selected effective length

$$a = \frac{1}{4} \cdot \left(L_b - \frac{d_{bF} + d_{bk}}{2} \cdot \pi \right) + \frac{1}{4} \cdot \sqrt{\left(L_b - \frac{d_{bF} + d_{bk}}{2} \cdot \pi \right)^2 - 2 \cdot (d_{bF} - d_{bk})^2}$$

$$a = \frac{1}{4} \cdot \left(2477 - \frac{605.5 + 112}{2} \cdot \pi \right) + \frac{1}{4} \cdot \sqrt{\left(2477 - \frac{605.5 + 112}{2} \cdot \pi \right)^2 - 2 \cdot (605.5 - 112)^2} = 626.38 \text{ mm}$$

Arc of contact around the small pulley

$$\beta = 2 \cdot \arccos \left(\frac{d_{bF} - d_{bk}}{2 \cdot a} \right)$$

$$\beta = 2 \cdot \arccos \left(\frac{605.5 - 112}{2 \cdot 626.38} \right) = 133.6^\circ$$

Take-up and installation allowances x and y

$$x = \frac{0.008 \cdot L_b}{\sin \frac{\beta}{2}}$$

$$x = \frac{0.008 \cdot 2477}{\sin \frac{133.6}{2}} \approx 22 \text{ mm}$$

$$y = \frac{0.005 \cdot L_b + \pi \cdot h_f \cdot \frac{\beta}{360}}{\sin \frac{\beta}{2}}$$

$$y = \frac{0.005 \cdot 2477 + \pi \cdot 6 \cdot \frac{133.6}{360}}{\sin \frac{133.6}{2}} \approx 21 \text{ mm}$$

h_f from Table 22, page 28

Belt speed

$$v = \frac{\pi \cdot d_{wF} \cdot n}{60 \cdot 10^3}$$

$$v = \frac{\pi \cdot 118 \cdot 700}{60 \cdot 10^3} = 4.32 \text{ m/s}$$

Flex frequency

$$f_B = \frac{10^3 \cdot v \cdot k}{L_b + 2 \cdot \pi \cdot h_b}$$

$$f_B = \frac{10^3 \cdot 4.32 \cdot 2}{2477 + 2 \cdot \pi \cdot 3} = 3.46 \text{ s}^{-1}$$

Power correction factor for arc of contact

c_{1F} from Table 32, page 49

$$c_{1F} = 0.86$$

Length factor

c_3 from Table 21, page 25

$$c_3 = 1.03$$

Power capacity

P_R from Table 30, page 42

$$P_R = 1.48 \text{ kW}$$

Number of ribs required

$$z_{er} = \frac{P \cdot c_2}{P_R \cdot c_{1F} \cdot c_3}$$

$$z_{er} = \frac{10 \cdot 1.3}{1.48 \cdot 0.86 \cdot 1.03} = 9.92$$

design choice:

- 1 CONTI-V MULTIRIB® Belt 10 PL 2477 ZAR
- 1 multi-groove pulley P 10 PL 112
- 1 flywheel $d_a = 600 \text{ mm}$

Check the service factor

$$c_{2er} = z \cdot \frac{P_R \cdot c_{1F} \cdot c_3}{P}$$

$$c_{2er} = 10 \cdot \frac{1.48 \cdot 0.86 \cdot 1.03}{10} = 1.31$$

Effective pull

$$F_u = \frac{P \cdot 10^3}{v}$$

$$F_u = \frac{10 \cdot 10^3}{4.32} = 2315 \text{ N}$$

Total span tension

$$F_v = (k_1 \cdot F_u + 2 \cdot k_2 \cdot v^2 \cdot z) \cdot \sin \frac{\beta}{2}$$

$$F_v = (2.09 \cdot 2315 + 2 \cdot 0.037 \cdot 4.32^2 \cdot 10) \cdot \sin \frac{133.6}{2}$$

$$F_v = 4460 \text{ N}$$

k_1 from Table 23, page 30

$$k_1 = 2.09$$

k_2 from Table 24, page 30

$$k_2 = 0.037$$

Check the installation tension of the Multiple V-Ribbed Belt

Static tension per rib

$$F = \frac{F_v}{2 \cdot z \cdot \sin \frac{\beta}{2}}$$

$$F = \frac{4460}{2 \cdot 10 \cdot \sin \frac{133.6}{2}} = 242.6 \text{ N}$$

See Fig. 8, page 31 for force applied per rib

$$F_{\text{eges}} = z \cdot F_e$$

$$F_e = 20 \text{ N}$$

$$F_{\text{eges}} = 10 \cdot 20 = 200 \text{ N}$$

Installation tension value from Fig. 8, page 31

$$\frac{t_e}{L_f} \cdot 100$$

$$\frac{t_e}{L_f} \cdot 100 = 1.9$$

Free span length

$$L_f = a \cdot \sin \frac{\beta}{2}$$

$$L_f = 626.38 \cdot \sin \frac{133.6}{2} = 575.73 \text{ mm}$$

Deflection of the belt

$$t_e = \frac{L_f}{100} \cdot \text{Installation tension value}$$

$$t_e = \frac{575.73}{100} \cdot 1.9 \approx 11 \text{ mm}$$

With this deflection, the belt installation tension is in conformity with the theoretical desired value.

ContiTech drive design service

Designers of complicated and series drives are recommended to contact the Application Engineers of ContiTech Power Transmission Systems Ltd.

Computer-aided design calculations are carried out competently and reliably in close cooperation with customers.

Fig. 11 shows the computer printout for the two-pulley drive given as an example on page 46.

ContiTech Power Transmission Systems ContiTech Group of Continental AG		CONTITECH	
<u>CONTI-V MULTIRIB® DRIVE CALCULATION</u>		04.12.2001	15:38:31
Customer :	Example of calculation	Company :	ContiTech
Reference :	Grinder	Telephone :	0511-938 - 71
:	:	Fax :	0511-938-5232
:	:	Designer :	H.Menssen
Belt Type:		CONTI-V MULTIRIB®	
Section:		PJ	
Effective Diameter Of Small Pulley:		DBK =	40,00 mm
Pitch Diameter Of Small Pulley:		DWK =	42,40 mm
Effective Diameter Of Large Pulley:		DBG =	125,00 mm
Pitch Diameter Of Large Pulley:		DWG =	127,40 mm
Speed Of Small Pulley:		NK =	8550,00 rpm
Speed Of Large Pulley:		NG =	2845,53 rpm
Drive Ratio:		I or 1/I =	3,00
Belt Effective Length:		LBER =	711,00 mm
Calculated Centre Distance:		AER =	221,84 mm
Arc of Contact:		BETA =	157,51 degree
Take Up:		X +	5,80 mm
Slack Off:		Y -	7,13 mm
Belt Speed:		V =	18,98 m/s
Belt Flex Frequency:		FB =	52,83 Hz
Power To Be Transmitted:		P =	3,700kW
Given Service Factor:		C2 =	1,20
Arc Of Contact Factor:		C1 =	0,94
Belt Length Correction Factor:		C3 =	0,92
Power Rating Per Rib:		PR =	0,88 kW
Calculated Number Of Ribs:		ZER =	5,76
Recommended Number Of Ribs:		Z =	6
Calculated Service Factor:		C2ER =	1,25
Min. Pulley Face Width:		B2 =	15,30 mm
Belt Tension Factor:		K1 =	1,85
Belt Rotational Force:		FU =	194,93 N
Static Tension Per Belt:		FGES =	200,16 N
Static Axle Load:		FV =	392,63 N
Dynamic Axle Load:		FDYN =	353,19 N
Test Force Per V-Ribbed Belt:		FEGES =	60 N
Belt Tension Test Deflection:		TE =	11 mm
Natural Frequency Of Belt Span:		EIF =	141,70 Hz
Service Life:		LH >	25000 Hrs
<hr/>			
Result:			
1 CONTI-V MULTIRIB(r) Belt		6 PJ 711	
Small Pulley		P6 PJ 40,00	
Large Pulley		P6 PJ 125,00	

Computer printout for calculating a drive with a CONTI-V MULTIRIB® Multiple V-Ribbed Belt

Fig. 11

Tensioning idlers

Inner tensioning idlers

Back-tensioning idlers

Serpentine drives

Crossed drives

Notes on design

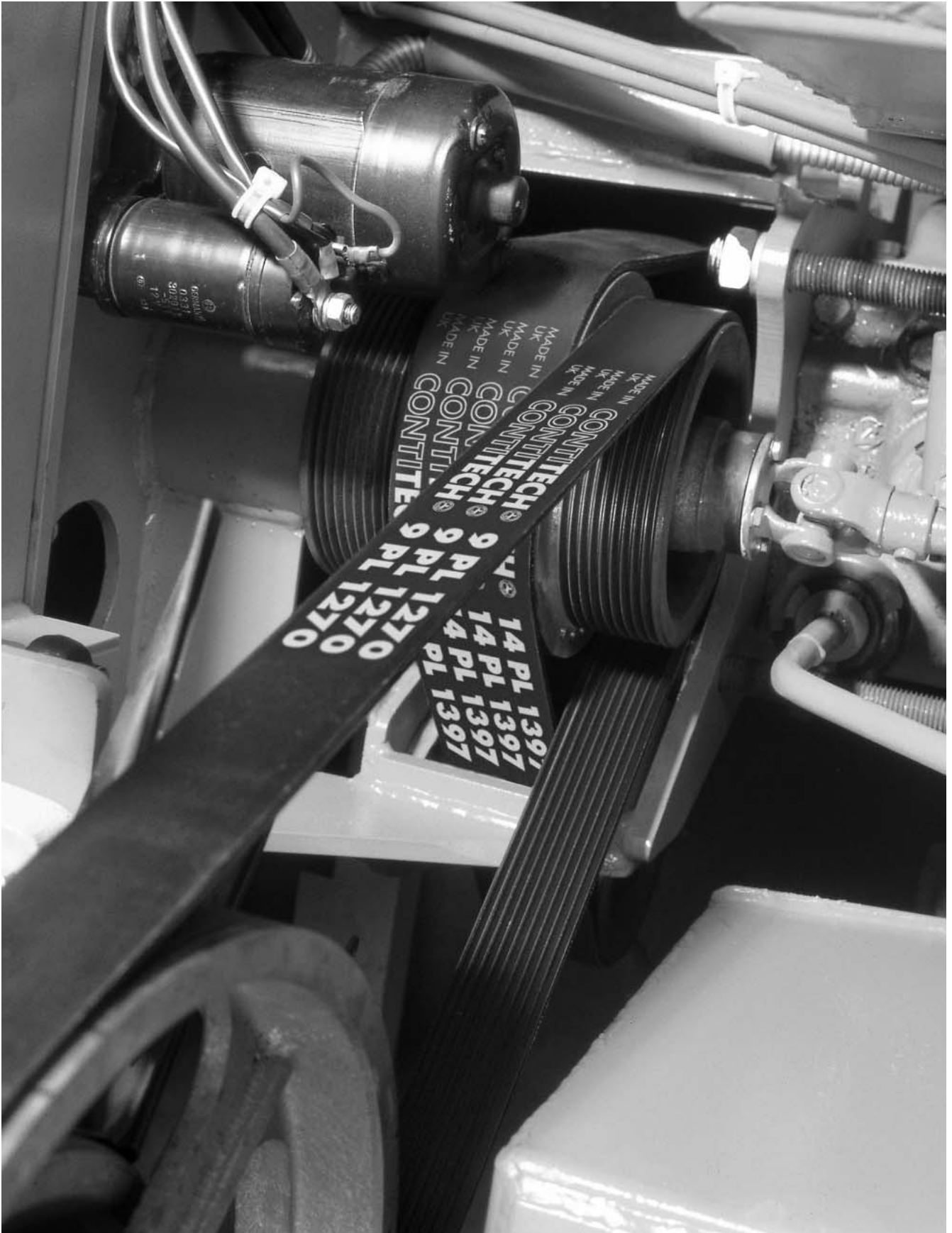

CONTI-V MULTIRIB® Multiple V-Ribbed Belt
in a lane-marking machine

Notes on design

The following notes are intended to help drive designers make the best possible use of the various product properties of CONTI-V MULTIRIB® Multiple V-Ribbed Belts. Designers of complicated and series drives are recommended to contact ContiTech's Application Engineers for technical advice, without any obligation.

Tensioning idlers

The high flexural strength of CONTI-V MULTIRIB® Multiple V-Ribbed Belts allows drives with fixed centre distances to make easy use of back-tensioning or inner tensioning idlers. The inclusion of low-weight spring and damper units or hydraulic tension systems enables maintenance-free drive types with high smooth-running properties to be achieved even with varying loads.

The tensioning rollers should have the largest feasible diameter. The minimum diameters for inner and outer tensioning idlers are shown in Table 35.

Tensioning idlers should, if possible, be positioned in the slack side of the drive. Exact lateral alignment must be ensured to prevent belt mistracking.

For applications involving a shaking motion – e.g. vibrators or drives with clutch functions – the tensioning idlers should be provided with flanges to prevent the belt from slipping off.

Inner tensioning idlers

Tensioning idlers acting from the inside outwards decrease the arc of contact. So they should always be placed near the large pulley.

Inner tensioning idlers must be designed with the matching rib profile.

Reverse-tensioning idlers

Tensioning idlers acting on the back of the belt increase the arc of contact and boost the tensioning capacity of the drive. The use of reverse-tensioning idlers is hence particularly recommended for drives with large transmission ratios and short centre distances. They should be positioned in the slack side near the small pulley.

Reverse-tensioning idlers should be smooth and cylindrical with diameters not smaller than the following:

Minimum diameter for tensioning idlers

Table 35

Section code		PH	PJ	PK	PL	PM
inner tensioning idler	mm	13	20	45	75	180
back-tensioning idler	mm	40	50	75	150	360

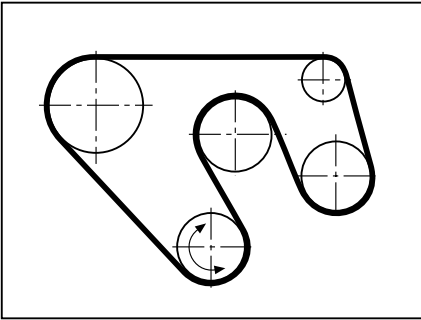

Serpentine drives

The very high flexibility and flexural strength of CONTI-V MULTIRIB® Multiple V-Ribbed Belts allows counter-flexing and the use of pulleys with small diameters. This in turn allows compact and economical configurations, e.g. serpentine drives with several driven pulleys.

At the same time, the smooth back of CONTI-V MULTIRIB® Multiple V-Ribbed Belts can also be used for power transmission.

Speed increasing drives

When calculating speed increasing drives the crucial factor is not the power rating of the drive pulley, but the power rating P_R as well as the rpm n_k for the effective diameter d_{bk} of the small driven pulley.

Crossed drives

CONTI-V MULTIRIB® Multiple V-Ribbed Belts are also suitable for drive configurations with non-parallel arranged shafts. They do not require the use of special pulleys.

Crossed drives inevitably involve a twisting of the Multiple V-Ribbed belts. The optimum design of the belt arrangement of the pulleys can frequently only be determined by experimentation.

The following notes and illustrations explain examples of half-crossed Multiple V-Ribbed belt drives with or without tensioning rollers.

Half-crossed Multiple V-Ribbed belt drives with back-tensioning rollers

Half-crossed Multiple V-Ribbed belt drives with back-tensioning rollers allow large transmission ratios with relatively small centre distances without any extra step-down gears or intermediate shafts. A reverse operation is also possible provided there is an appropriate design of back-tensioning rollers.

The smooth and cylindrical back-tensioning roller should be approx. 75 mm wider than the Multiple V-Ribbed belts used. The values shown in Table 35 apply to the minimum roller diameter. The back-tensioning roller should be arranged on the slack side near the small pulley.

The following points should be observed when designing and installing:

The centre distance ① should not be less than the value calculated by the following formula.

$$a_{\min} = 22.5 \cdot \text{width of the Multiple V-Ribbed belt in mm.}$$

The back-tensioning roller ② should be installed with the following angle of inclination:

$$\psi = 112 \cdot \frac{d_{bk}}{a} \text{ in } ^\circ(\text{degrees})$$

For drives with a constant direction of motion the tension roller is to be designed so that the belt centre line ③ is situated at right angles to the axis and in the middle of the cylindrical surface.

Drives with a reversal in the direction of motion must include a tensioning roller adjustable both in the direction of the inclination and in the cross direction. The optimum position must be determined by experimentation.

The taut side ④ runs twisted by 90° to the drive pulley.

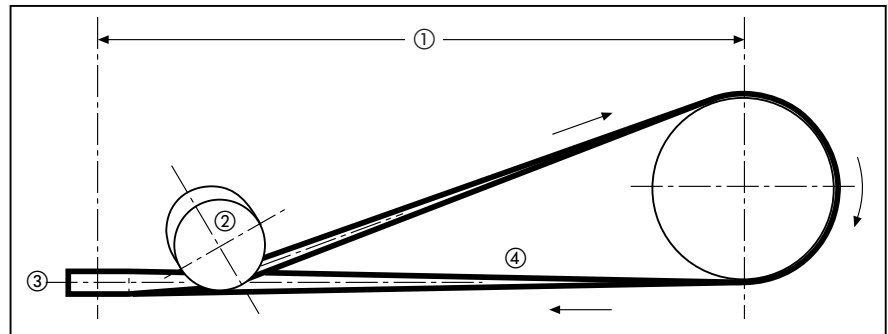

Top view

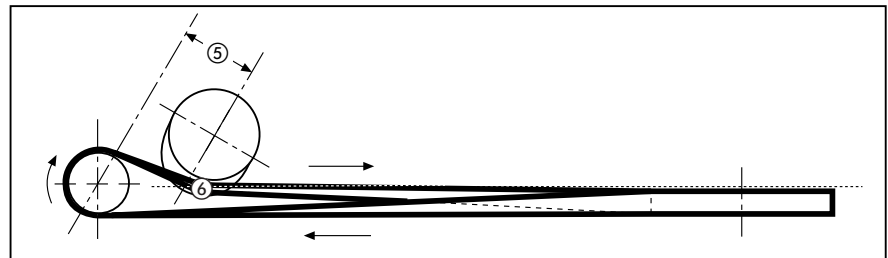

Side view

The distance a ⑤ between the drive pulley and the tensioning roller should not be less than e, where

$$e = 4 \cdot b + 75 \text{ mm}$$

The back-tensioning roller is correctly arranged when the point of contact ⑥ of the belt centre line on the tensioning roller lies in the same plane or slightly higher than the outside of the driven pulley.

Half-crossed Multiple V-Ribbed belt drives without tensioning rollers

Half-crossed Multiple V-Ribbed belt drives without tensioning rollers are not suitable for reverse operations.

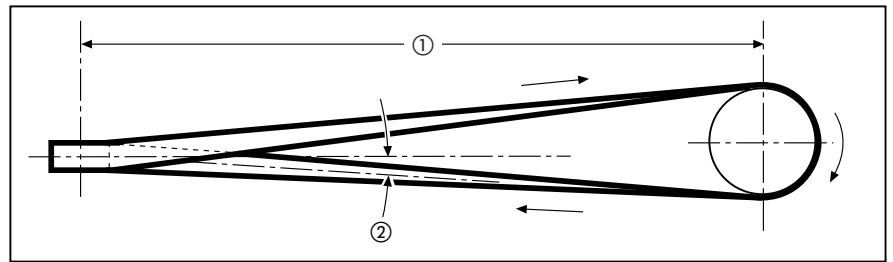

Top view

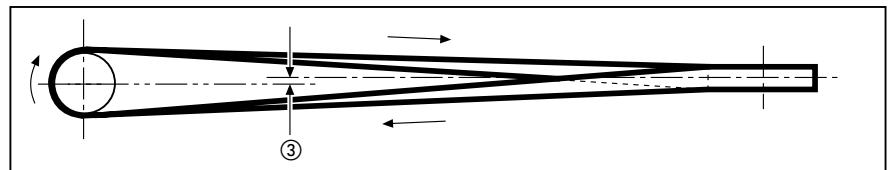

Side view

The following points should be observed when designing and installing:

For the minimum centre distance ① the larger of the following two values is to be chosen:

$$a_{\min} = 13 \cdot d_{bk} \quad \text{or} \quad a_{\min} = 5,5 \cdot (d_{bg} + 1,5 \cdot b)$$

The angle ② between the belt centre line in the run and the horizontal should not exceed 2° .

The driven pulley must lie in the same plane or only slightly higher than the centre of the drive pulley ③. The initial tension should be adjusted for maximum load so as to avoid a sag in the slack side.

Installation and storage of Multiple V-Ribbed belts

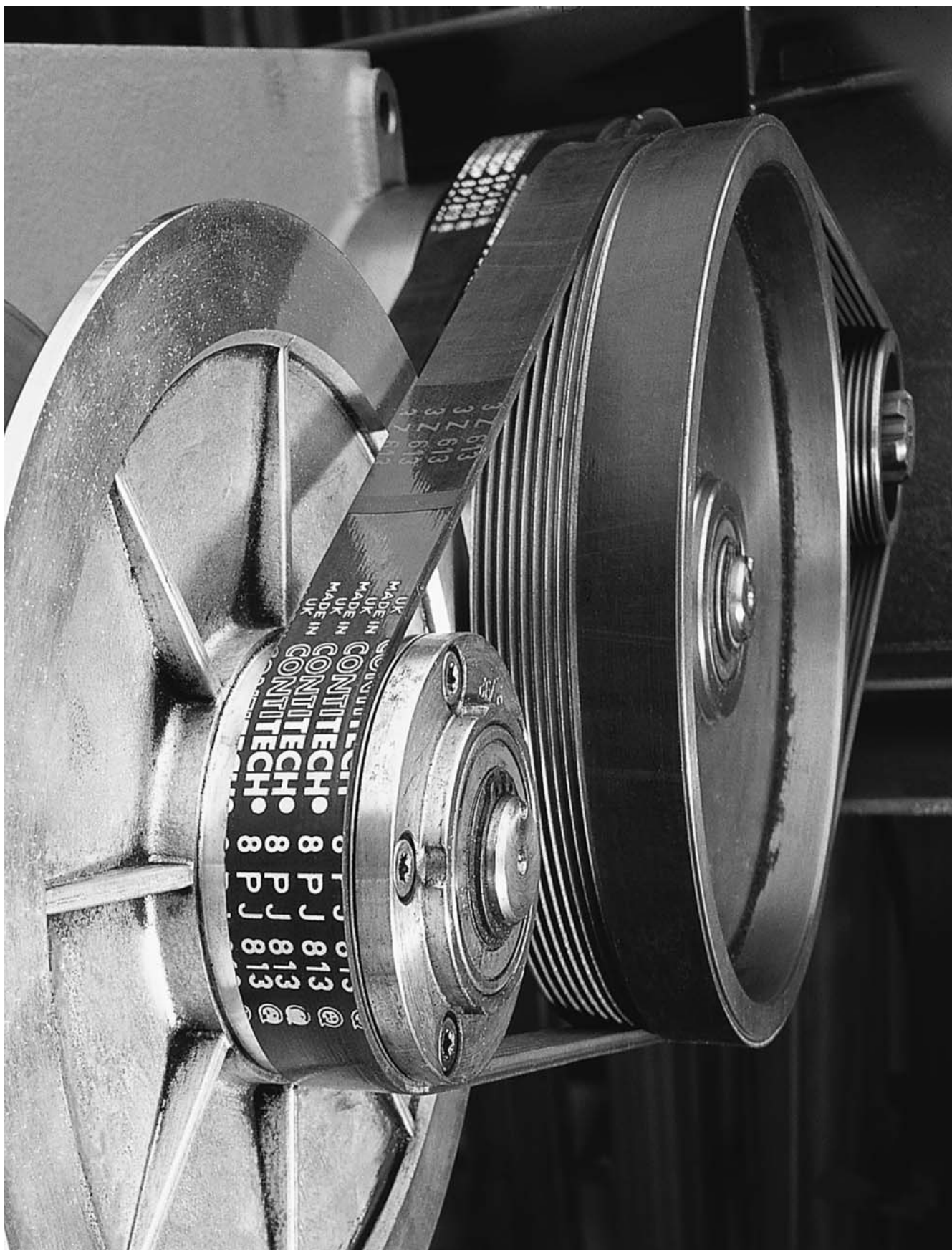

CONTI-V MULTIRIB® Multiple V-Ribbed Belts
in a tooling machine

Installation and storage of Multiple V-Ribbed Belts

Long belt life and reliable performance are ensured by CONTI-V MULTIRIB® Multiple V-Ribbed Belts provided that

- the drive is correctly designed using the right belt section and the right number of ribs and
- the instructions for storage and installation are observed.

Installation

The following recommendations will help you to fully utilise all the advantages of CONTI-V MULTIRIB® Multiple V-Ribbed Belts.

1. Pulleys must conform to the data given in the Section on “multi-grooved pulleys”. Wrong selection of the pulleys or the belt section will lead to poor drive performance.
2. All pulleys are to be correctly aligned and installed parallel to the axis. Pulley misalignment can result in belt mistracking, rib jumping, extreme belt edge wear and excessive drive noise.
 - Failures that can occur are:
 - Pulley misalignment ① – Move one of the pulleys along the shaft until both pulleys are properly aligned.
 - Shafts not parallel ② – Turn engine or drive unit until the pulleys are aligned.
 - Shafts not in one plane ③ – Realign units both shafts. Then check pulley alignment. Ensure compliance with notes in Section 4. The design notes contained on Page 57 are particularly important for crossed drives.
3. Pulleys must be free from burr, rust and dirt. Contaminated or damaged pulleys lead to premature belt damage.
4. On Installation, the belt should never be forced or prised over the pulley edges using a lever. This would cause imperceptible damage to the tension member and ribs and would shorten the belt life. Reduction of the centre distance will permit the belt to slide onto the pulley easily. In the untensioned state both slack and tight side should have the same sag.

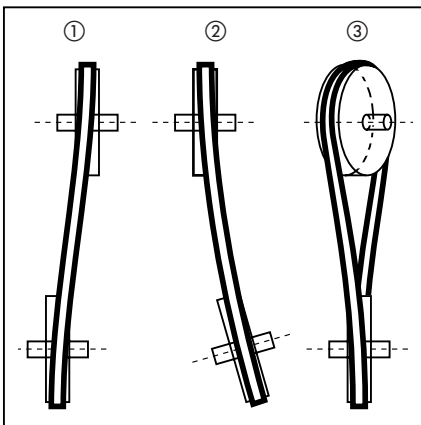

5. Multiple V-Ribbed Belt drives must be tensioned with great care. Insufficient tensioning leads to inadequate power transmission and premature wear on the belt due to slippage. Overtensioning causes excessive stretch, thereby reducing belt life, and gives rise to unnecessarily high wear on the bearings. See Page 48 on how to calculate and check the belt tension for new drives. All relevant data should be entered on the sticker shown in Fig. 12 and attached to the drive in a place that is easily visible.
6. After an initial running period of approx. 30 minutes under full load, installation tension must be checked and adjusted if necessary. If the belt is insufficiently tensioned, the slack side can sag, wobble or even slip off the pulley. Incorrectly tensioned Multiple V-Ribbed Belts are subject to premature wear.
7. It is important that no foreign matter, such as stones, metal fragments or sticky materials (e.g. tar), is allowed to become lodged between the pulley and the belt. If the service conditions make such lodging seem likely, the drive should be suitably protected. Otherwise, belt damage and premature failure may arise.
8. Multiple V-Ribbed Belts must be protected from oil spray, dripping oil and other chemicals. Constant exposure to such media would lead to swelling or other structural changes in the belt and consequently to premature failure.
9. If tensioning idlers are used, the design notes on Page 56 should be observed.

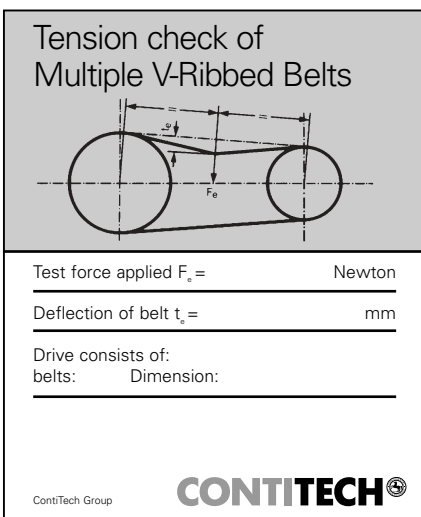

Sticker for entering tension data

Fig. 12

If these instructions are followed CONTI-V MULTIRIB® Multiple V-Ribbed Belts will reward you with reliable operation.

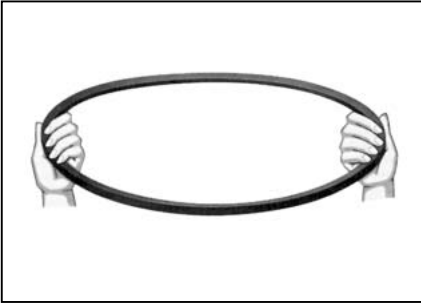

*Coiling long
Multiple V-Ribbed Belts*

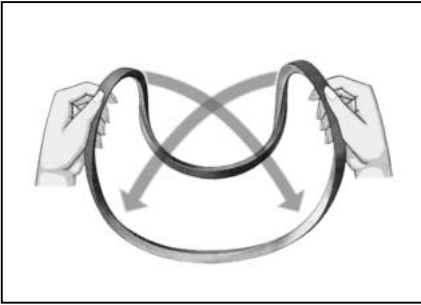

Fig. 13

Storage

General guidelines on the storage, cleaning and maintenance of rubber and plastic products are contained in DIN 7716.

How to store belts

Multiple V-Ribbed Belts are best stored by suspending them in cantilever type shelves or on large-diameter tubular brackets. The diameter should be at least 10 times the height of the belt cross section.

Long belts may be stacked to save space. However they must be coiled correctly as shown in Fig. 13.

Short belts may be stored on shelves, but stacks should not be more than 300 mm high to avoid deformation of the bottom belts.

Multiple V-Ribbed Belts for precision engineering applications are best stored on reels.

Hooks and nails are unsuitable for suspending Multiple V-Ribbed Belts.

Where to store belts

The storage room should be cool, dry, well ventilated and free from draughts. Storage temperature should be between 15 and 25 °C.

Keep Multiple V-Ribbed Belts away from direct heat.

Avoid direct sunlight and strong artificial light with a high UV content.

Ozone-generating equipment, e.g. sparking electrical switchgear, should not be in constant operation in the storage room.

A

Abrasion-resistant	6
Acceleration drives.....	57
Aramid tension member	7
Arc of contact	20, 24, 49
Available sizes	7
Axial runout	14
Axis, parallel to	12

B

Back idler pulleys	56
Base construction	5
Belt height	7
Belt length	9
Belt life	6
Belt pulleys	12–15
Belt section	7
Belt speed	28
– maximum	7, 12, 28
Belt stretch	29
Belt width, permissible	26
Borderline cases	26
Burr	62

C

Calculation	22, 49
Centre distance	27
Centrifugal force factor	29, 30
Characteristic data	7
Chemicals	42
Conductivity, tested electrical	7
Construction	5
Corroded pulleys	12
Correct alignment	62
Counter-flexing	5
Cover	5
Cross-section of pulley grooves	13
Curvature	50

D

Definitions	22, 23
Deflection	31, 48, 53
Design power calculation	14
Designations	6, 13
DIN 7716	63
DIN 7867	6, 9, 12–14
DIN code	7
Direct heat	63
Dirt	62
Dripping oil	62
Drive calculation data	24
Drive noise	62
Driven machine	25
Drives	8
– sure-grip tooth engagement	4
– high-speed	5
Driver	25
Dynamic stress	6

E

Economy	12, 26
Edge wear	62
Effective circumference	9
– of pulley	9
Effective diameter	9, 12–15, 51
– minimum	13
Effective length	6, 9, 27, 49
Effective line differential	7, 14, 49
Effective pull	53
Efficiency	6
EL (tested electrical conductivity)	7
Elastomer	5
Encasing compound	5
Enclosed drives	22
Example of design procedure	46, 51

F

Face width	13
Flat pulley	12, 49, 50
Flex frequency	5, 29
Flexibility	4, 5
Force applied	31
Foreign matter	62
Free from burr	12
Frequent stops and starts	25
Frictional engagement	5, 6

G

Groove angle	13
Groove profiles	8
Groove profile dimensions	13
Groove spacing	13

H

Hard-wearing	5, 6
Heavy shock	21
Height factor	18
Height of stacks	63

I

Installation	62
Installation of a	
Multiple V-Ribbed belt.....	28, 62
Installation tension	29, 62
– excessive	29, 62
– insufficient	29, 62
Installation tension factor	30
Installation tension graphs	31

L

Length calculation	9, 27, 49
Length factor	25
Length measurement	9
Length tolerance	9
Lengths, available	8
Load-bearing element	29
Load distribution	5, 6
Low-vibration	6

M

Maintenance	63
Measuring method	9
Measuring pulleys	9
Measuring tension	9
Multi-grooved pulleys	12
– materials	12
– sizes	13
Multiple V-Ribbed belt installation	
tension	29–31
Multiple V-Ribbed belt sizes	7

N

Number of grooves	13
Number of ribs	6, 29, 42

O

Oil-resistant, moderately	6
Oil spray	62
Operational hours	25
Ozone	63
Ozone-resistant	6

P

Performance	29
Pitch diameter	14, 22
Polychloroprene	5
Polyester cords	5
Power capacity rating	32–45
Power correction factor for arc	
of contact	24, 49
Power transmission capacity	4, 29
Properties	5
– standard	6
Protection of drive system	62
Pulleys	
– materials	12
– misalignment	62
– sizes	13
– standard range	15–19
Pulley diameters	12–19
– minimum	7, 56
– recommended	12
Pulley grooves	8

Q

Quiet operation	6
-----------------	---

R

Radial runout	14
Radius	
– bottom	13
– top	13
Range of sizes	8
Reliability	12, 62
Restricted length tolerance	7
Reversal in motion	58
Reverse-tensioning idlers	4, 5, 56
Retensioning	28, 62
Rib dimensions	7
Rib spacing	7
Ribs	5
– number of	6, 29
Rod	9
Roughness index	14

S

Section, choosing the	26
Section sizes, available	7
Serpentine drives	57
Service conditions	25, 30
Service factor	25
Service life	12, 29, 62
Service temperature	6
Shaft bearings	29, 62
Sizes	
– Multi-grooved pulleys	13
– Multiple V-Ribbed belts	7
Slack side	62
Slip	29, 62
Smooth running	6
Soiling	62
Span length	31, 48
Special compound	5
Special types	7
Speed changes	6
Stack heights	63
Static tension	30
Sticker for belt tension data	62
Storage	63
Storage room	63
Stretch	
– excessive	62
– low	5
Surface finish	14
Surface pressure	29
Symbols	22, 23

T

Take-up and Installation _____ 28
 allowances _____ 28
 Taper bush _____ 19
 Temperature range _____ 6
 Tension adjustment _____ 46
 Tension member _____ 5, 62
 Tensioning _____ 28
 Tensioning idlers _____ 25, 56
 Tolerances _____ 14
 – belt lengths _____ 9
 – axial runout _____ 14
 – effective diameter _____ 14
 – radial runout _____ 14
 Torque _____ 25
 Tracking _____ 6
 Transmission _____ 5, 27
 Tropical climates _____ 6
 Twisting _____ 6
 Two-pulley drive _____ 26, 29

U

Units _____ 22, 23

V

Variable speed drives _____ 21
 V-flat drives _____ 6, 49

W

Weathering _____ 6
 Wear-resistant _____ 5
 Weight per rib _____ 7

ContiTech Antriebssysteme GmbH
Postfach 445, D-30004 Hannover
Philipsbornstraße 1, D-30165 Hannover
Phone + 49 (0) 511 / 9 38-71
Fax + 49 (0) 511 / 9 38-52 37
E-Mail: industrie.as@antriebssysteme.contitech.de
www.contitech.de/antriebssysteme

ContiTech Antriebssysteme GmbH
Continentalstraße 1, D-29451 Dannenberg
Phone +49 (0) 58 61 / 8 06-0
Fax + 49 (0) 58 61 / 8 06-302
E-Mail: dannenberg@antriebssysteme.contitech.de

The contents of this publication are the result of many years of research and experience gained in application technology. All information is given in good faith; it does not represent a guarantee with respect to characteristics and does not exempt the user from testing the suitability of products and from ascertaining that the industrial property rights of third parties are not violated. No liability whatsoever will be accepted for damage – regardless of its nature and its legal basis – arising from advice given in this pub-

lication. This does not apply in the event that we or our legal representatives or management are found guilty of having acted with intent or gross negligence. No liability is borne for damage due to ordinary negligence. This exclusion of liability applies also to the personal liability of our legal representatives and employees and other persons employed in performing our obligations.
©2002 by ContiTech Holding GmbH, Hannover.
All rights reserved.